

TCORX
FITNESS IN MOTION

INSTRUCTION



TRX 40 S EVO



Rev : 00

Ed : 03/17



CONTENT

CONTENT	1
IMPORTANT SAFETY PRECAUTIONS	2
TECHINICAL PARAMETERS	3
PRODUCT OVERVIEW	3
ASSEMBLY INSTRUCTIONS	4
FOLDING & UNFOLDING INSTRUCTIONS	7
GROUNDING METHODS	8
OPERATION GUIDE	9
GETTING STARTED GUIDE	14
WARM-UP EXERCISES	15
SAFETY EXERCISES	16
MAINTENANCE INSTRUCTIONS	17
BELT ADJUSTMENT	18
EXPLODED DRAWING	19
PARTS LIST	20
ERROR CODE AND SIGNIFICANCE	21

removed. Note the power cord of motorized treadmill made by special equipment, and if it is broken, please contact distributor quickly.

15. The treadmill is for home use only.

16. The treadmill maximum user weight is 100kgs

17. Please do not over-use the treadmill so can avoid any injury and do not use incorrect way for your safety.

18. When the treadmill is not being used, please keep the safety pull pin in the safety place to avoid the other use.

Technical Parameters

Input supply voltage : 220V	Working temperature: 0-40 °C
Speed range: 0.8-16KM/H	Incline range:12 level Motor incline
Max. user weight: 100kg	Distance display range: 0.00-99.9km
Calories display range: 000-999	Time display range: 00 : 00-99 : 59 (min : sec)
Heart rate range: 50-200 (time / min)	Running surface: 420*1300mm
Product size: 1700*710*1380MM	Folding size: 900*710*1510MM



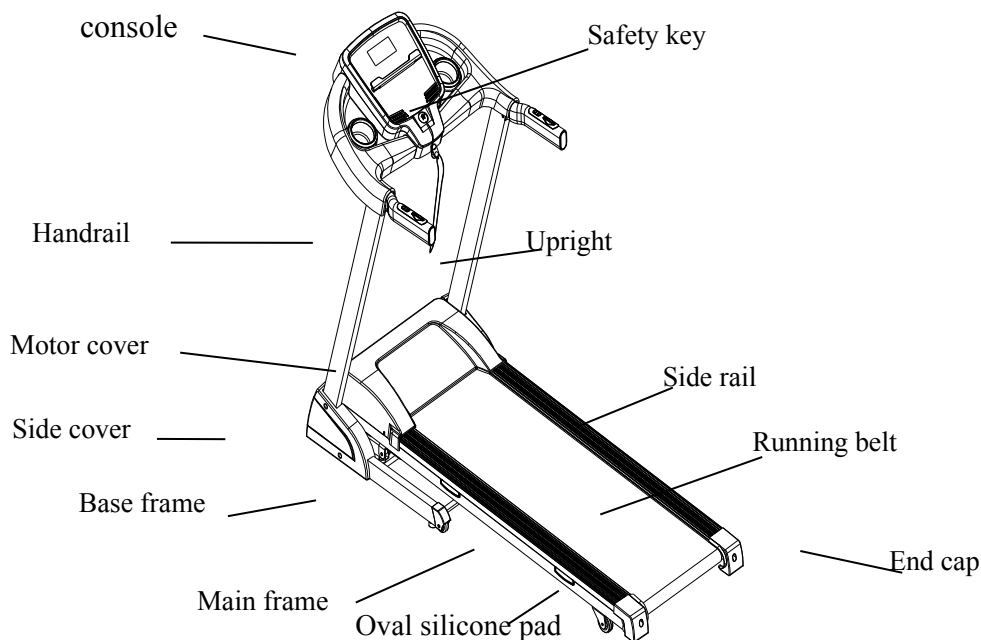





Product Overview

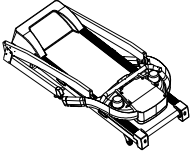

Assembly instruction

WHEN YOU OPEN THE CARTON, YOU WILL FIND THE BELOW SPARE PARTS:

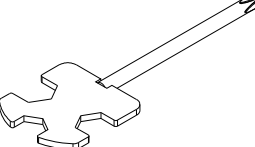
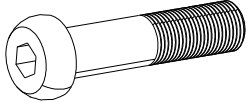
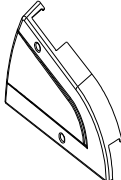
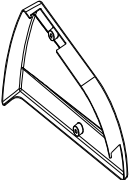
STEP 1: Take out and prepare the below parts

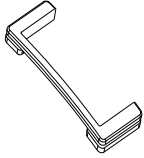
<p>1 Main frame 1 set</p> 	<p>D17 Inner star washer M8 8 PCs</p> 	<p>D13 Round hex bolt M8*15 4 PCs</p> 	<p>C13 Safety key 1 set</p> 
<p>D3 Allen wrench 5MM, 1 PC</p> 	<p>B18 Silicon oil 1 PC</p> 	<p>D1Screw driver 1PC</p> 	<p>D16Round hex bolt M8*45 4 PCs</p> 
<p>B11L Left side cover 1 PC</p> 	<p>B11R Right side cover 1 PC</p> 	<p>D48 Cross self-tapping bolt with washer ST4.2*19 4 PCs</p> 	<p>B12 Rubber cover 2 PCs</p> 

Note: Don't tighten bolts at once.

STEP 2: According to the following steps to lift up the uprights.

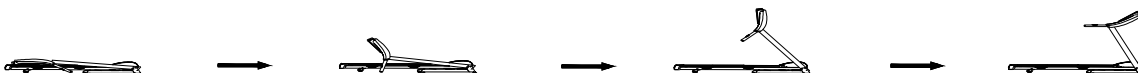

STEP 3: Secure bottom frame with bolt M8*45 (D16) , M8*15 (D13) and inner star washer (D17). Then assemble the console bracket with bolt M8*15 (D13) and inner star washer (D17).

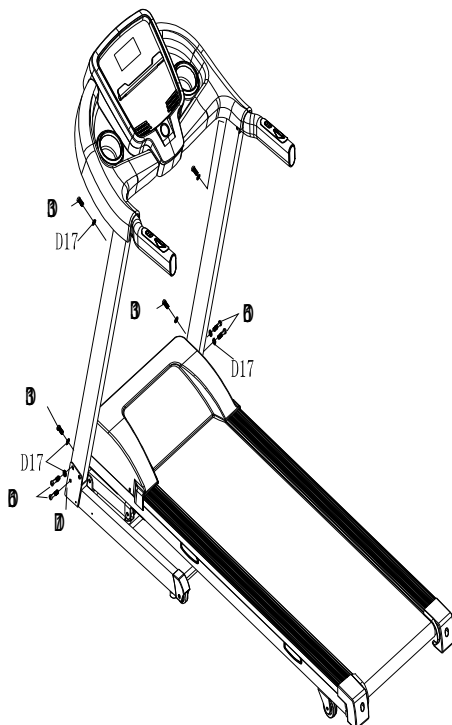

Step 4: Tighten the rubber cover (B12) to the left/right side covers (B11L/R) with cross self-tapping bolt with washer ST4.2*19 (D48).

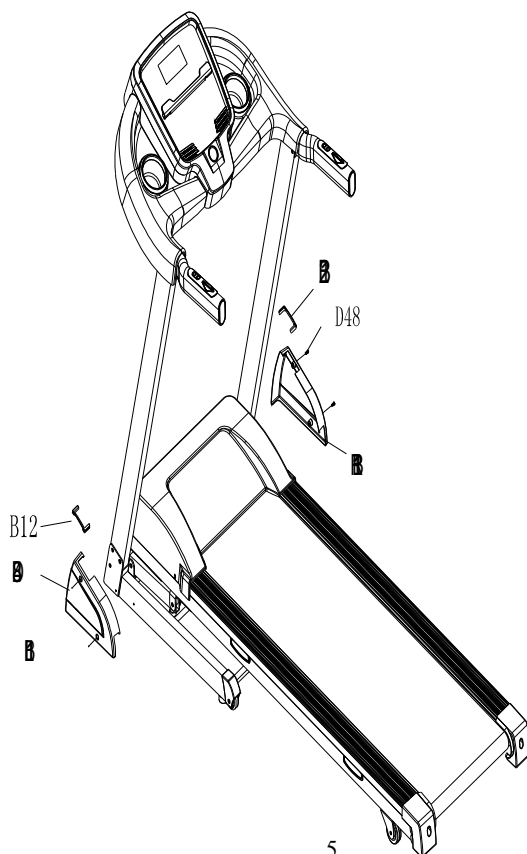

Step 5: Place on the safety key (C13).

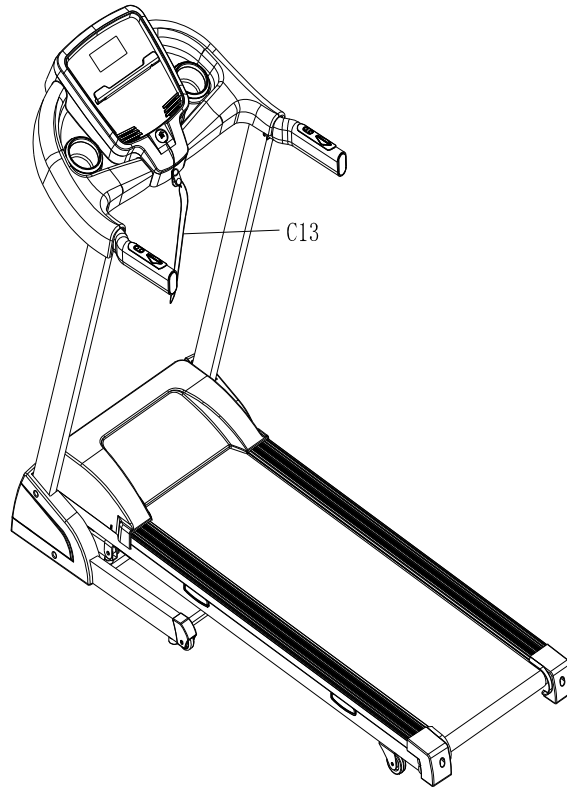

Step 6: To check if the running belt runs correctly, placing treadmill in folding position and tightening all the bolts. Then set speed under 3km/h and see if running belt runs without problem.

Folding Instruction

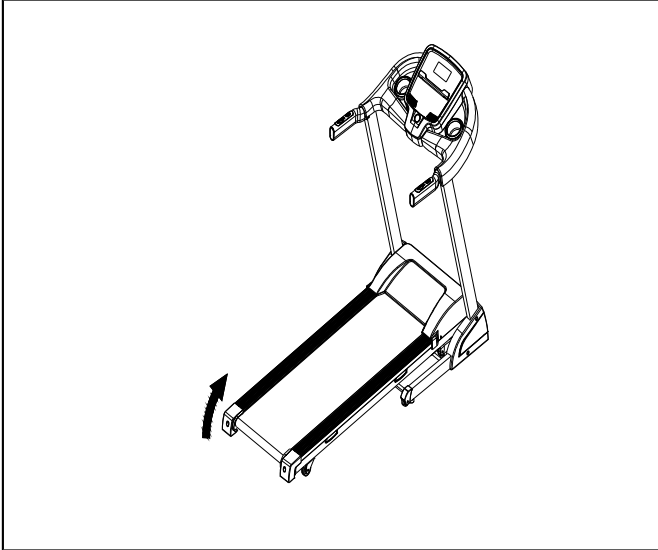

Lift up the machine and force to pull up until you heard "click" that made by safety casing stuck the pneumatic cylinder.

Unfolding instruction

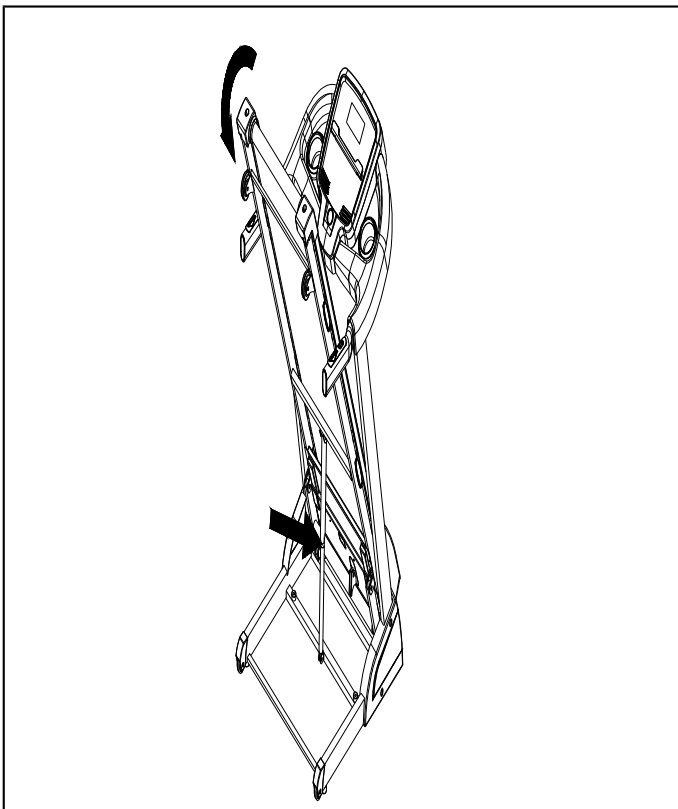

Kick the safety sleeve lightly and pull down the machine at the same time as the arrow direction. Then the machine will fall down smoothly.

Grounding Methods

This product must be grounded. If it should malfunction or breakdown, grounding provides path of least resistance for electric current to reduce the risk of electric shock. This product is equipped with a cord having an equipment-grounding conductor and a grounding plug. The plug must be plugged into an appropriate outlet that is properly installed and grounded in accordance with all local codes and ordinances.

DANGER – Improper connection of the equipment-grounding conductor can result in a risk of electric shock. Check with a qualified electrician or serviceman if you are in doubt as to whether the product is properly grounded. Do not modify the plug provided with the product – if it will not fit the outlet, Please find a proper outlet installed by a qualified electrician.

. This product is for use on a nominal 240V circuit and has a grounding plug. Make that the product is connected to an outlet having the same configuration as the plug. No adapter should be used with this product.

Operation Guide

1.1. WINDOW DISPLAY

1.1. Console



1.2. START

Normal start after 5 seconds countdown

1.3 PROGRAM

3 countdown functions, 12 sets of programs, 1 body fat program

1.4. SAFETY LOCK FUNCTION

The window shows "---" when take away the safety lock and the treadmill will stop quickly with "didi" alarm noise. And put the safety lock on, the computer will display for 2 seconds and the date count down to "0"

1.5.BUTTON FUNCTION

1.1.1. START/STOP

"START"--When the treadmill is not running, press this button to start, speed is "0.8"

"STOP"--When the treadmill is running, press this button to stop, then set program default and then return to manual mode after stopped.

1.5.2 "PROGRAM" BUTTON

When the treadmill is not running, press this button can choose from program circle mode to manual mode (P1-P12). The lowest speed for manual mode is “0.8km/h”, and the highest speed is “16km/h”; the lowest incline is “0”, and the highest is “12”.

1.5.3 “MODE” BUTTON

When the treadmill is not running, press this button to choose countdown modes:”H-1”,”H-2”,”H-3”.

H-1” is the time countdown mode, and “H-2” is the distance countdown mode, “H-3” is the calories countdown mode.

Press the “SPEED+/-” or “INCLINE+/-“button to adjust the data. After that, press the “START” button to start this treadmill

1.5.4 “SPEED +/- “BUTTON

SPEED +/- --Adjust speed when treadmill start, the increment is 0.1km/time in kilometer. Press the button more than 2 seconds, and it will be up or down automatically.

1.5.5 “INCLINE+/-” BUTTON

INCLINE +/- – --Adjust incline when treadmill start; the increment is 1 level/time. Press the button more than 2 seconds, and it will be up or down automatically

1.5.6 SPEED QUICK BUTTON

Press the speed quick button 3km/h, 6km/h, 9m/h, 12km/h to adjust the speed directly when the treadmill is running

1.5.7 INCLINE QUICK BUTTON

Press the incline quick button 3,6,9,12 to adjust the incline directly when the treadmill is running

1.6. DISPLAY FUNCTION

1.6.1 TIME

Display the running time or countdown time

1.6.2 SPEED

Display running speed

1.6.3 INCLINE

Display the incline

1.6.4 PULSE

Display pulse data

1.6.5 DISTANCE

Display the running total distance or distance countdown.

1.6.6 CALORIES

Display the calorie or calorie countdown

1.6.7 SPEED DIAGRAM

Display the diagram of the running speed

1.6.8 ALL WINDOW DISPLAY DATA RANGE

TIME : 0:00 – 99.59(MIN)

DISTANCE: 0.00 – 99.9(KM)

CALORIES: 0.0 – 999 (C)

SPEED:0.8 -16.0 (km/h)

INCLUDE: 0-12%

PULSE: 50 – 200 (BPM)

1.7 PULSE FUNCTION

When the treadmill is running, hold the hand pulse about 5 seconds, it will display pulse data. The pulse data range is 50-200 times/ minute. It has heart-shaped graphics when testing pulse. This data is only for reference, can not be as medical data.

1.2. PROGRAM EXERCISE CHART

There are 10 sections in each program.

TIME MODE		SET TIME / 16 = TOTAL TIME IN EACH OPERATION									
		1	2	3	4	5	6	7	8	9	10
P1	SPD	3	3	6	5	5	4	4	4	4	3
	INC	0	3	3	3	4	4	4	1	1	0
P2	SPD	3	3	4	4	5	5	5	6	6	4
	INC	2	2	2	3	3	3	3	4	4	2
P3	SPD	2	4	6	8	7	8	6	2	3	2
	INC	3	5	4	4	3	4	4	3	4	2
P4	SPD	3	3	5	6	7	6	5	4	3	3
	INC	0	3	3	2	2	5	5	3	3	2
P5	SPD	3	6	6	6	8	7	7	5	5	4
	INC	3	5	3	4	2	3	4	2	3	2

P6	SPD	2	6	5	4	8	7	5	3	3	2
	INC	3	4	5	6	3	5	5	6	4	3
P7	SPD	2	9	9	7	7	6	5	3	2	2
	INC	0	3	3	3	4	4	4	1	1	0
P8	SPD	2	4	4	4	5	6	8	8	6	2
	INC	1	1	4	4	4	5	5	4	3	2
P9	SPD	2	4	5	5	6	5	6	3	3	2
	INC	3	5	3	4	2	3	4	2	3	2
P10	SPD	2	5	7	5	8	6	5	2	4	3
	INC	1	5	6	8	12	9	10	9	5	3
P11	SPD	2	5	6	7	8	9	10	5	3	2
	INC	3	5	6	8	6	5	8	7	5	2
P12	SPD	2	3	5	6	8	6	9	6	5	3
	INC	5	7	5	8	6	5	9	10	6	2

1.9 3 COUNTDOWN FUNCTION PARAMETER DATA

Countdown time initial setting 10 : 00 minutes , setting range 5 : 00---99 : 00 minutes , each step 1 : 00.

Countdown calorie initial setting 50therm, setting range 20---990 therm , each step 10.

Countdown distance initial setting 1.0km , setting range 1.0---99.0 km , each step 0.1

Cycle switch order is: manual, time, distance, calories.

1.10 BODY TESTER (FAT)

At the beginning state, press “ PROGRAM” continually to enter “FAT“ body fat test , window display “FAT”. Press “MODE” to enter (F1 SEX, F2 AGE, F3 HEIGHT, F4 WEIGHT). Press “SPEED+”, “SPEED-” to set. After setting, the computer will display F5 and grasp the hand pulse, the window will display your body quality index.

The body quality index is to test the relation between height and weight not the body scale.

The body FAT suits for any male and female to adjust the weight according together with other body quality index. The ideal FAT should be between 20-25, if under 19, it means too thin. If between 25 and 29, it means overweight, if over 30, it means obesity. (The data is just for reference and can not be as medicinal data)

01 Sex 01 Male 02 Female

02 Age 10-----99

-
- 03 Height 100---200
04 Weight 20-----150
05 FAT ≤19 Under weight
FAT = (20---25) Normal weight
FAT = (25---29) Over weight
FAT ≥30 Obesity

1.11 OTHERS

1.11.1 When the countdown mode is finished and “END” appears on screen, warning sound occurs . Then it will be back to manual mode.

1.11.2 You can set statistics at circled mode. Ex: When time is set at 5:00 – 99:00 and it hits 99:00, press “+” button, it will start from 5:00 again.

1.11.3 Countdown time, countdown calorie and countdown distance, you just can set one of them at

one time, press last item to set running, the setting parameter is countdown, others display normal data.

1.11.4 Speed control: acceleration at 0.5km/s; deceleration at 0.5km/s.

Maintenance Instruction

WARNING : Please make sure pull out the treadmill's power plug before cleaning or maintaining the product.

CLEANSING : General cleaning of the unit will greatly prolong the treadmill's life.

Keep treadmill clean by dusting regularly. Be sure to clean the exposed part of the deck on either side of the walking belt and also the side rails. This reduces the build up of foreign material underneath the walking belt. Make sure the shoes are clean. The top of the belt may be cleaned with a wet soapy cloth. Be careful to keep liquid away from inside the motorized treadmill frame or from underneath the belt.

WARNING : Always unplug the treadmill from the electrical outlet before removing the motor cover. At least once a year remove the motor cover and vacuum under the motor cover.

This treadmill's walking belt and deck are equipped with a pre-lubricated, low maintenance deck system. The belt/ deck friction may play a major role in the function and life of your treadmill, thus requiring periodic lubrication. We recommend a periodic inspection of the deck.

We recommend lubrication of the deck according to the following timetable:

Light user (less than 3 hours/ week)	Every 60 days
Medium user (3-5 hours/ week)	Every 45 days
Heavy user (more than 5 hours/ week)	Every 30 days

We suggest you buy lubricating oil from local distributors or contact our company directly.

Pay attention, any other maintains please ask professionals for help.

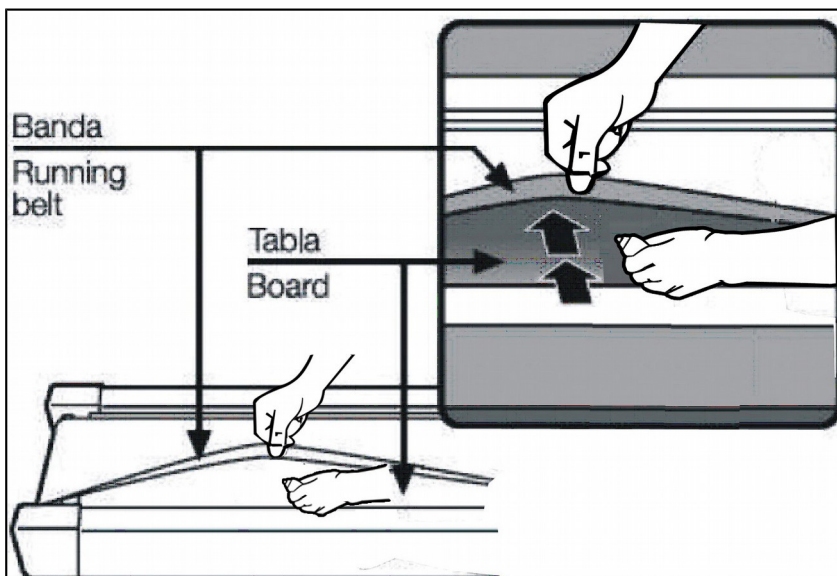

Belt Adjustment

Place treadmill on a level surface. Make treadmill run at approximately 6-8 km/h, observe the running belt deviate condition.

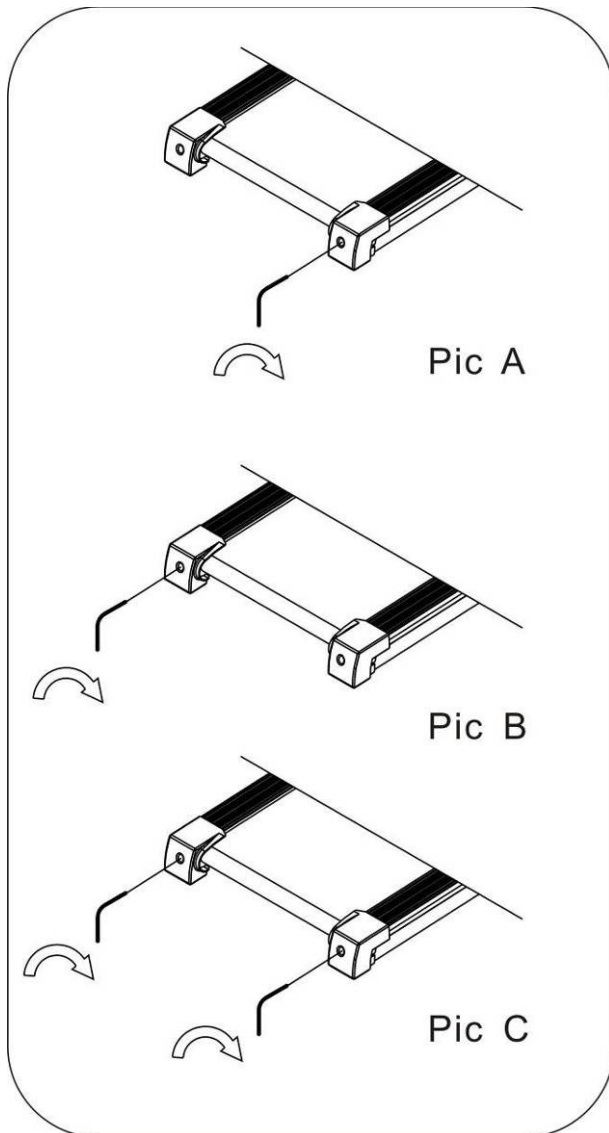

If the belt has drifted to the right, unplug the safety lock and power switch, and turn the right adjusting bolt 1/4 turn clockwise, then insert the power switch and safety lock, make the treadmill running, observe the running belt deviate condition. Repeat above steps until the running belt be placed in the middle. **See picture A**

Once the treadmill belt swerving to the left, unplug the safety lock, turn off the power, then with the left adjusting bolt clockwise rotation 1 / 4 laps, and turn on the safety lock and power to make treadmill running, checking the deviation of the treadmill belt. Repeat the above steps until the belt centered. **See picture B**

The treadmill belt will gradually relax after above steps or after a period of time using, unplug the safety lock, and turn off the power, with the two adjusting bolt clockwise rotation 1 / 4 laps, and turn on the safety lock and power to make treadmill running, then standing on the belt to confirm the tightness. Repeat the above steps until the belt moderate tightness. **See picture C**

Exploded Drawing

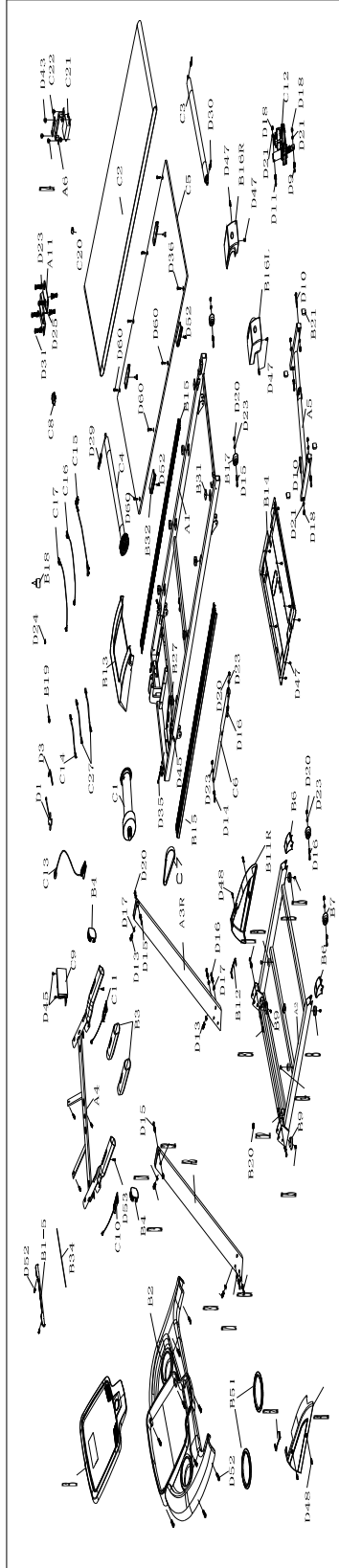

Parts List

A. Welding parts

No.	Description	QTY	No.	Description	QTY
A1	Main frame	1	A4	Console bracket	1
A2	Base frame	1	A5	Incline bracket	1
A3L	Left upright	1	A6	Filter bracket	1
A3R	Right upright	1	A11	Motor bracket	1

B. Plastic parts

No.	Description	QTY	No.	Description	QTY
B1	Console set	1	B13	Motor upper cover	1
B1-1	Overlay	1	B14	Motor lower cover	1
B1-2	Membrane keys	1	B15	Side rail	2
B1-3	Console	1	B16L	Left end cap	1
B1-5	Tablet holder	1	B16R	Right end cap	1
B2	Console cover	1	B17	Adjust wheel	2
B3	Protecting foam	2	B18	Silicon oil	1
B4	Handrail plug	2	B19	Cable organizer	1
B6	Transporting wheel plug	2	B20	Round plug	1
B7	Transporting wheel	2	B21	Squared shape plug	4
B8	Flat foot pad	2	B27	New cushion	6
B9	U shaped foot pad	2	B31	Rubber pad	2
B10	Limited cushion	2	B32	Oval silicone pad	4
B11L	Left side cover	1	B34	Rubber pad (for tablet holder)	1
B11R	Right side cover	1	B51	Water bottle cup holder	2
B12	Rubber cover	2			

C. Electric and drive parts

No.	Description	QTY	No.	Description	QTY
C1	DC motor	1	C12	Incline motor	1
C2	Running belt	1	C13	Safety key	1
C3	Rear roller	1	C14	Single cord	1
C4	Front roller	1	C15	Power cable	1
C5	Running deck	1	C16	Upper cable	1
C6	Cylinder	1	C17	Lower cable	1
C7	Motor drive belt	1	C20	Magnetic ring	1
C8	Power switch	1	C21	Inductor	1
C9	Controller	1	C22	Filter	1
C10	Left handrail button	1	C27	Single cord	2
C11	Right handrail button	1			

D. Hardware parts

No.	Description	QTY	No.	Description	QTY
D1	Screw driver 13-15-17	1	D25	Spring washer M8	4
D3	Allen wrench T5	1	D29	Hex round head bolt M6X45	1
D9	Round hex bolt M10X30	1	D30	Hex round head bolt M6x60	2
D10	Round hex bolt M10X45	4	D31	Hex round head bolt M8X20	4

D11	Round hex bolt M10*50	3	D35	Hex round head bolt M8X80	1
D13	Round hex bolt M8X15	4	D36	Cross head bolt M6X25	2
D14	Round hex bolt M8X30	1	D43	Cross head bolt M4X20, washer	2
D15	Round hex bolt M8X40	4	D45	Cross head bolt M5X15, washer	7
D16	Round hex bolt M8X45	7	D46	Cross head bolt M5x20, washer	2
D17	Inner star washer M8	8	D47	Cross self-tapping bolt ST4.2X16, washer	17
D18	Nylon nut M10	8	D48	Cross self-tapping bolt ST4.2X19, washer	4
D20	Nylon nut M8	8	D52	Cross self-tapping bolt ST4.2X16	17
D21	Flat washer M10	8	D53	Cross self-tapping bolt ST4.2x45	2
D23	Flat washer M8	13	D57	Cross self-tapping bolt ST4.2X25	4
D24	Spring washer M5	1	D60	Cross head bolt M6X20	6



GARLANDO SPA
Via Regione Piemonte, 32 - Zona Industriale D1
15068 - Pozzolo Formigaro (AL) - Italy
www.toorx.it - info@toorx.it