

**TOORX**  
FITNESS IN MOTION

# INSTRUCTION

**APP READY 3.0**



# ALTITUDE



Cod : GRLDTOORXALTTITUDE

Rev : 00

Ed : 08/23



# Assembly Steps



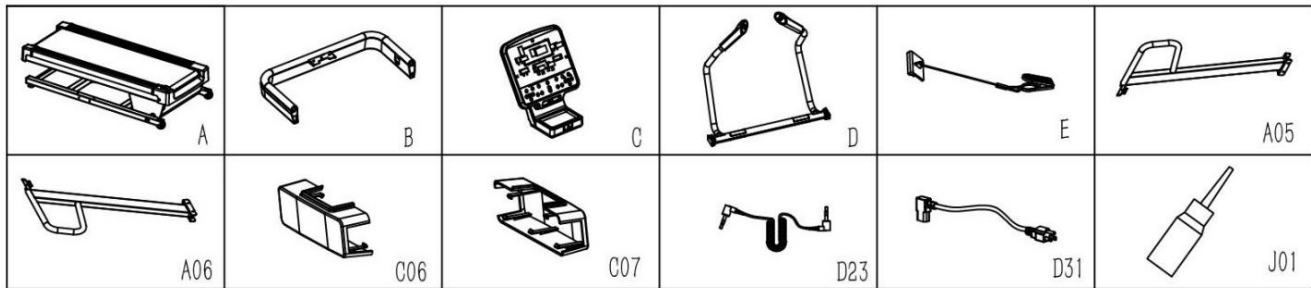





Please check the package list carefully before assembly.

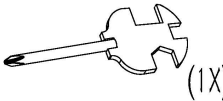
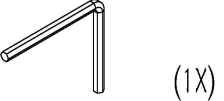
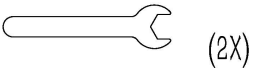
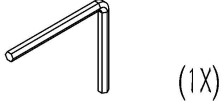

## Package list:

NO.	Description	Specification	QTY	NO.	Description	Specification	QTY
A	Mainframe		1	A06	Right upright column		1
B	Display frame		1	C06	Left bottom cover		1
C	Display		1	C07	Right bottom cover		1
D	Middle handlebar		1	D23	Mp3 connection wire		1
E	Safety key		1	D31	Power cable		1
A05	Left upright column		1	J01	Silicon oil		1

## Assembly tools:

B10 S=13 14 15  (1X)	B11 S5  (1X)	B12 17#  (2X)	B13 S6  (1X)
E03 M10  (4X)	E09 M10*70  (4X)	E11 M8*25  (4X)	E12 M8*15  (6X)
E16 M6*10  (3X)	E29 Ø8  (6X)	E40 M8*15  (4X)	

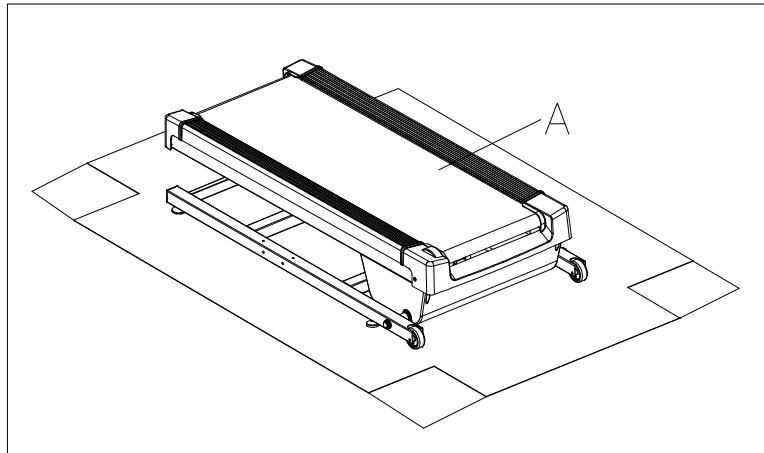

**Attention: please don't switch on before finish assembling.**

Step 1:

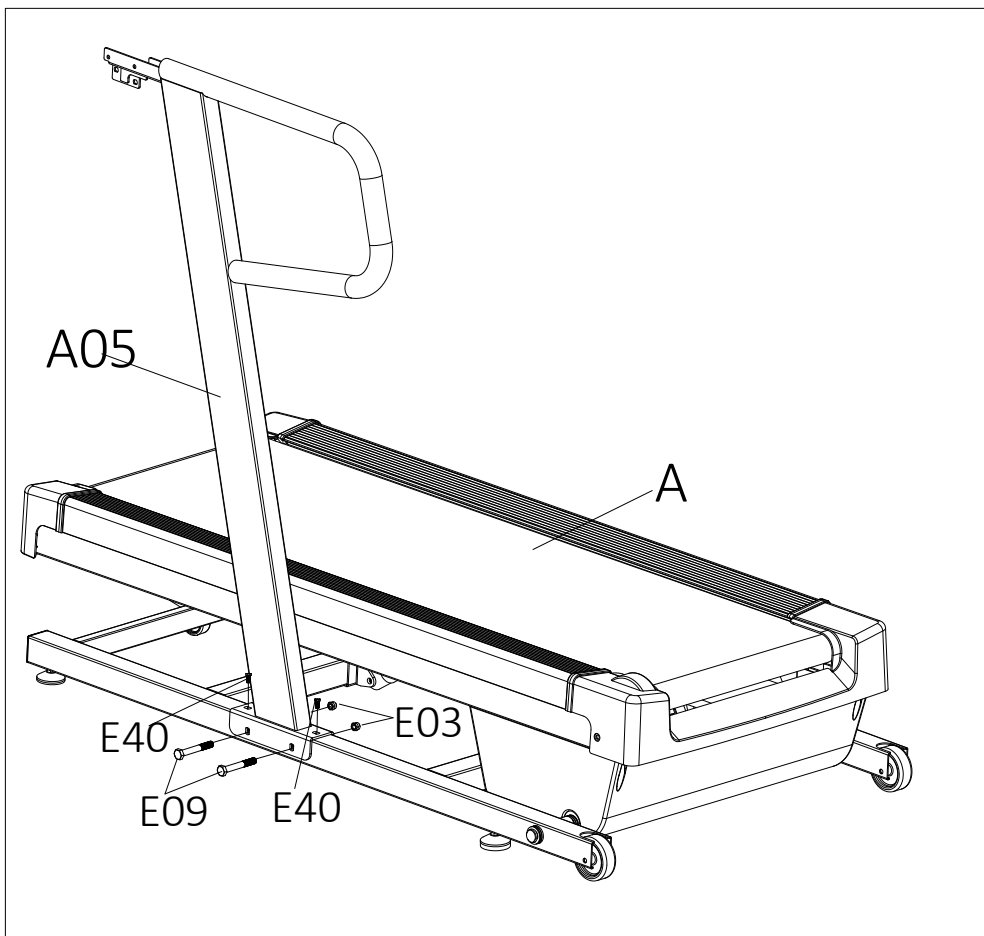

Step 2:

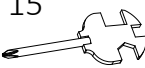

	E03 M10	E09 M10*70	E40 M8*15
	(2X)		(2X)
	B12 17#		B11
(2X)		15	S5
		(1X)	(1X)

step 3:

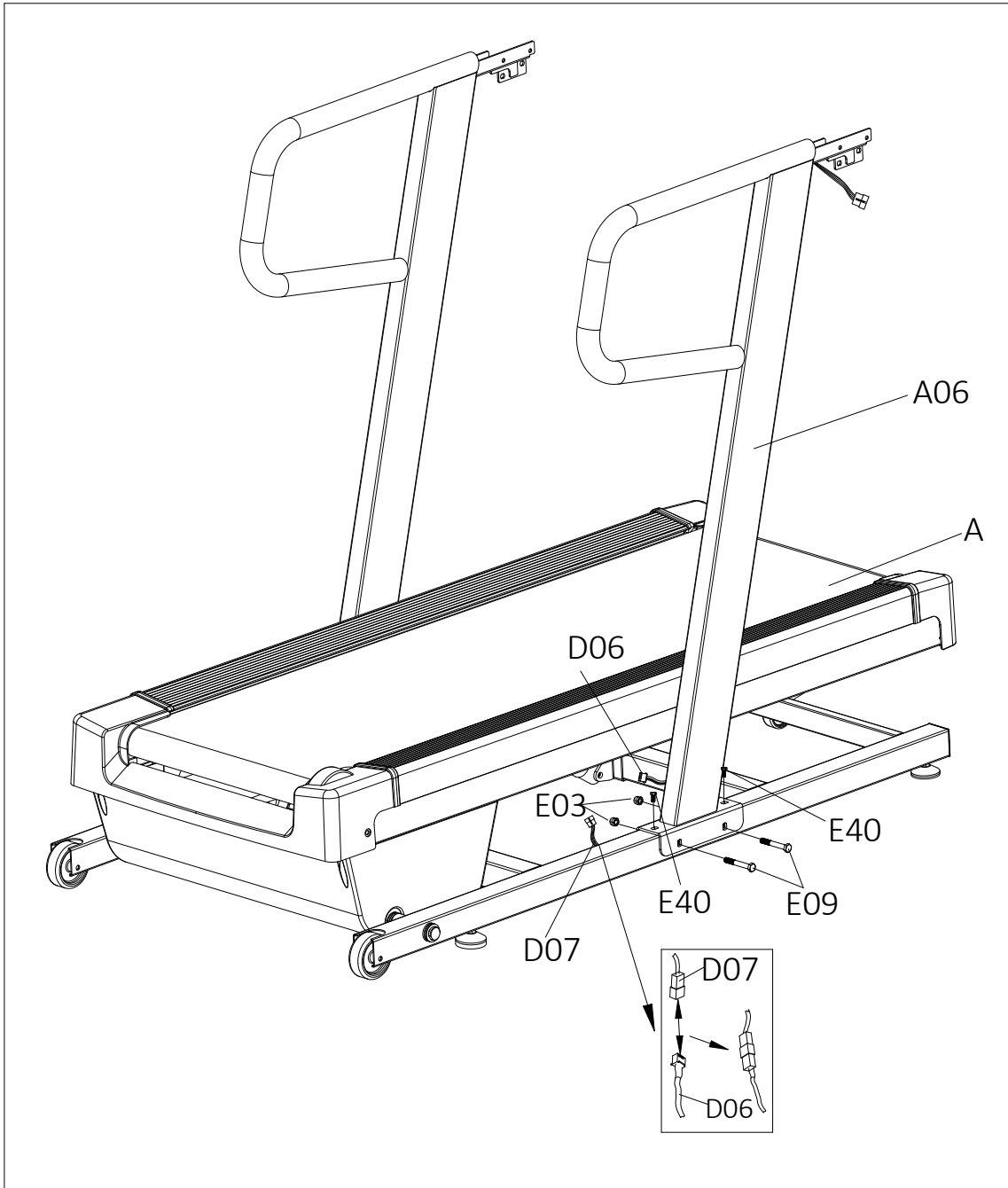

	E03 M10	E09 M10*70	E40 M8*15
	 (2X)	 (2X)	 (2X)
	B12 17#	B10 S=13 14	15 B11 S5
	 (2X)	 (1X)	 (1X)

**Step 4:**

**Note:** please remove the bottom cover of the display frame before assembling.

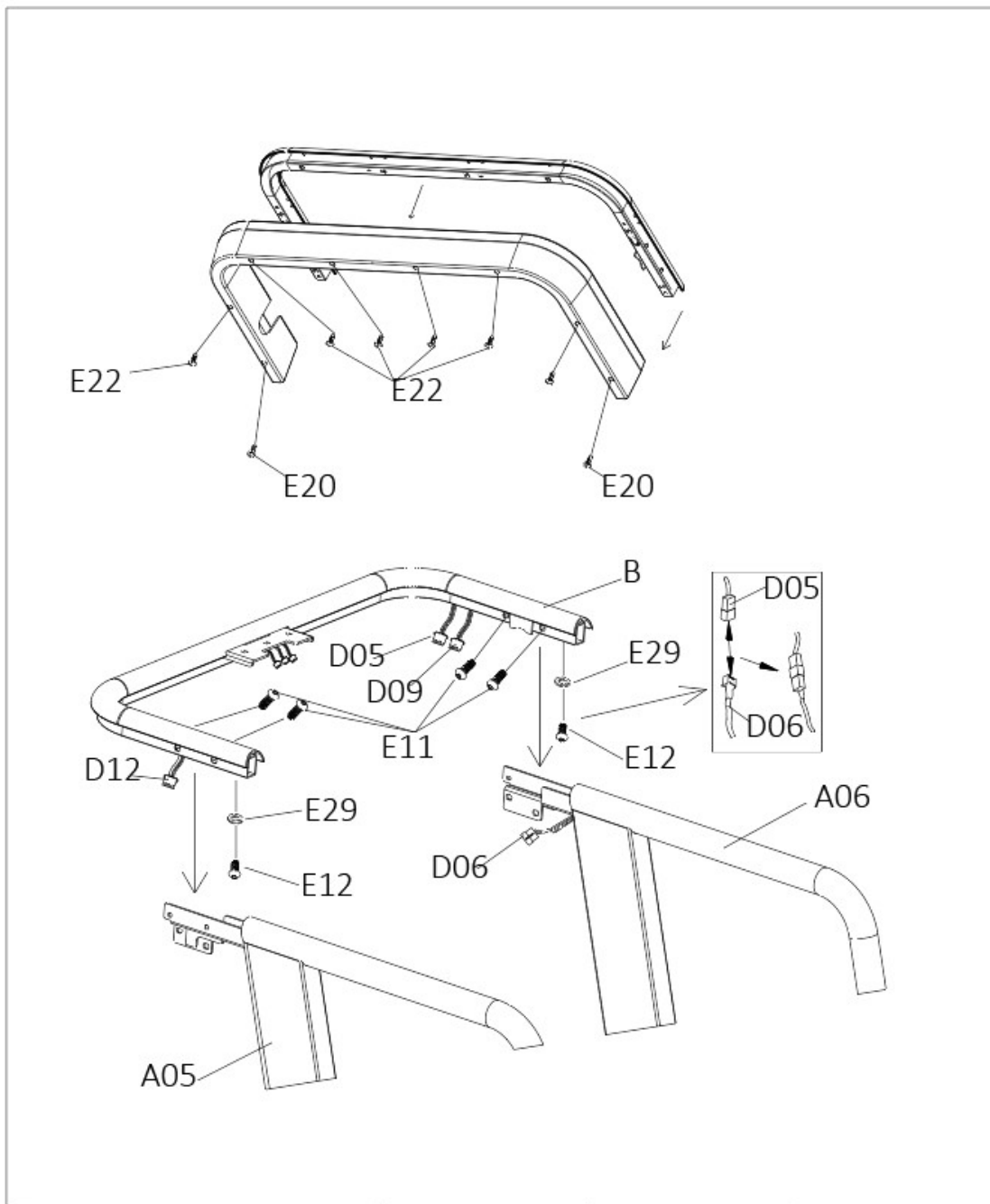

	E11 M8*25	E12 M8*15	E29 $\phi$ 8
	 (4X)	 (2X)	 (2X)
	B11 S5		
	 (1X)		

Step 5:

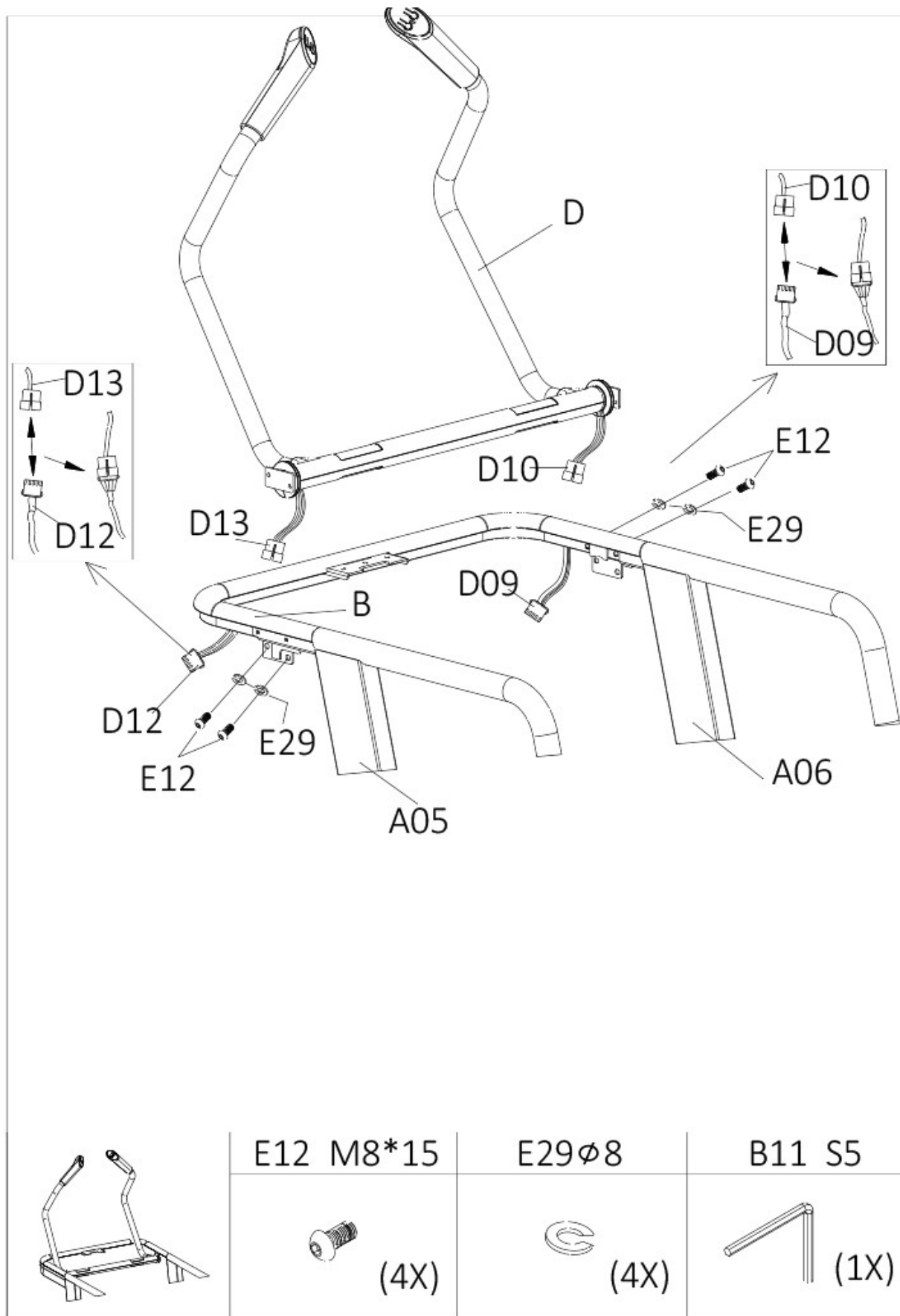

# Step 6

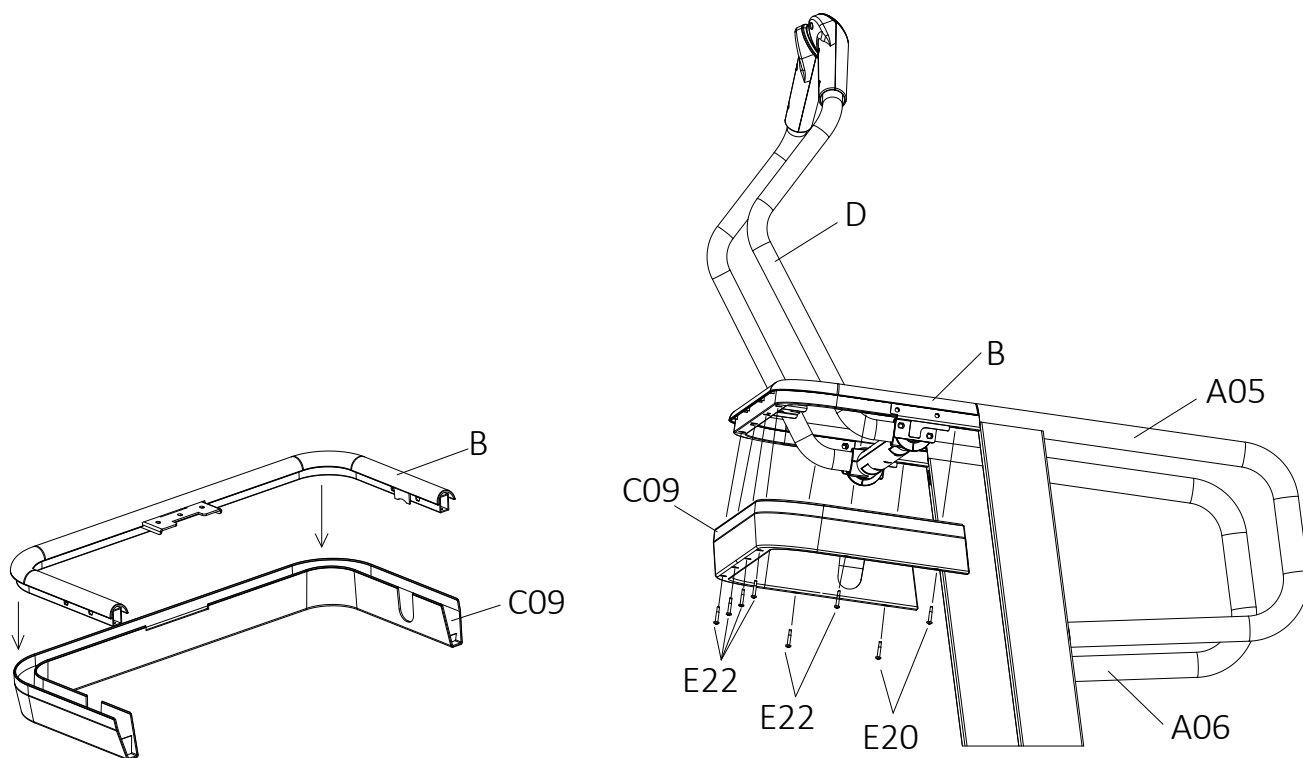

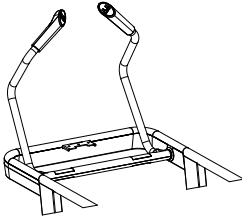
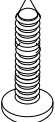
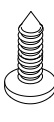
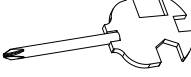
	<p>E20 ST4.2*25</p>	<p>E22 ST4.2*12</p>	<p>B10 S13 14 15</p>
	 <p>(2X)</p>	 <p>(6X)</p>	 <p>(1X)</p>

Step 7

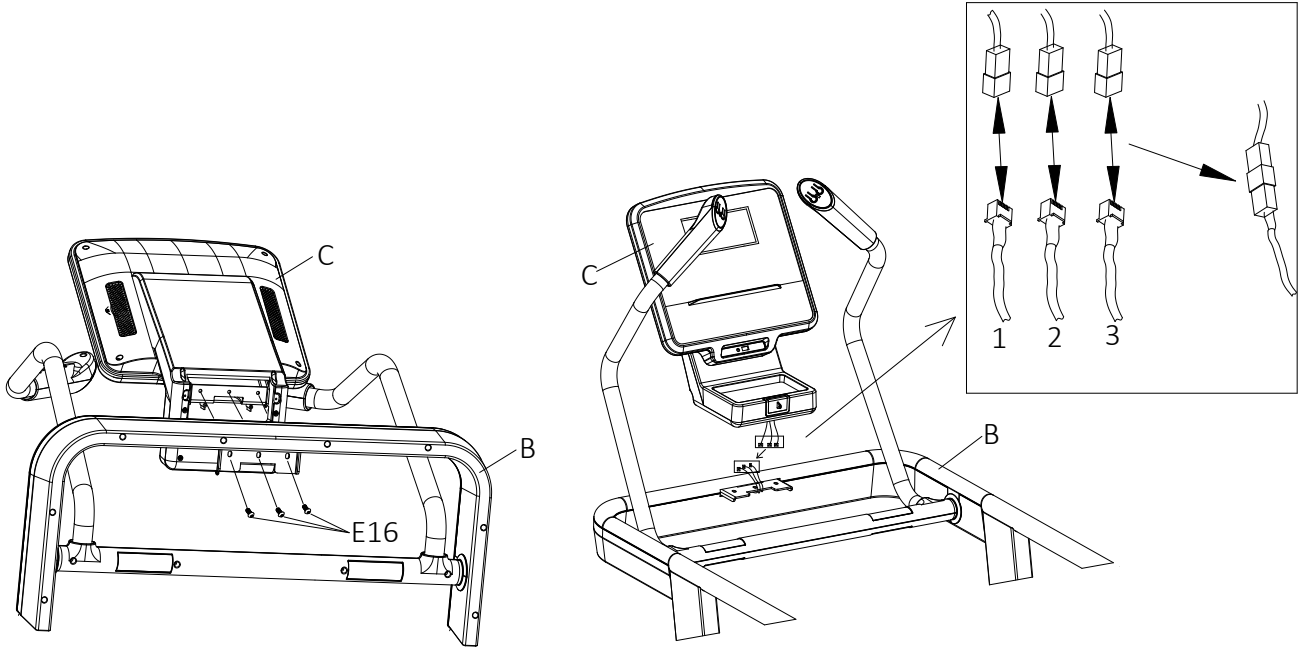

	E16 M6*10	B11 S5
	(3X)	(1X)

Step 8

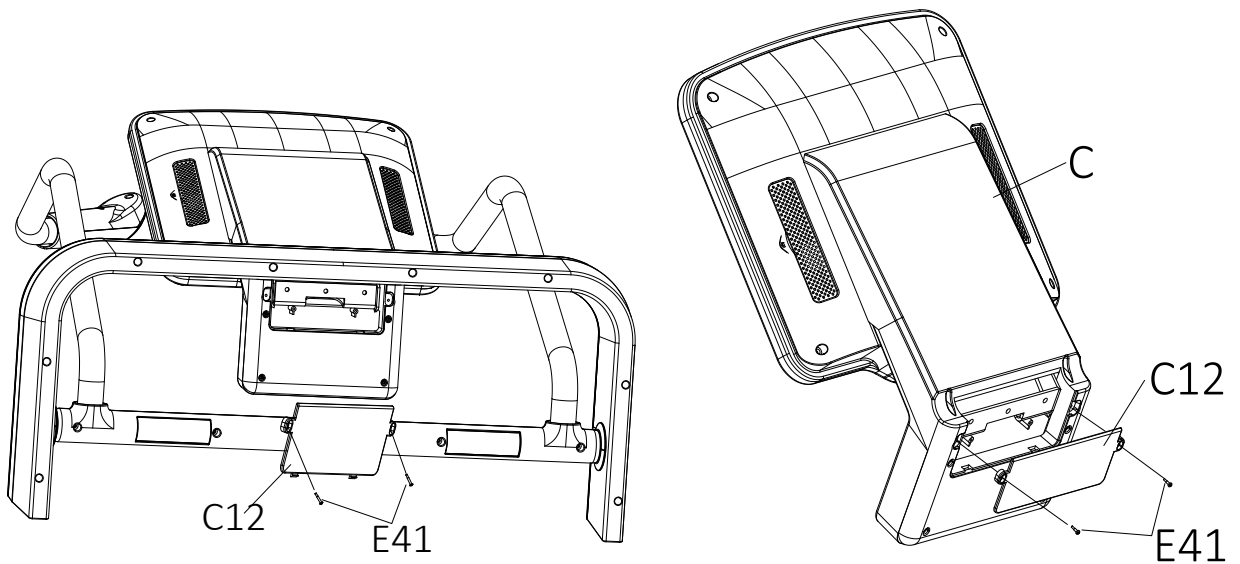

	E41 ST2.9*16	B10 S=13 14 15
	(2X)	(1X)



Step 9

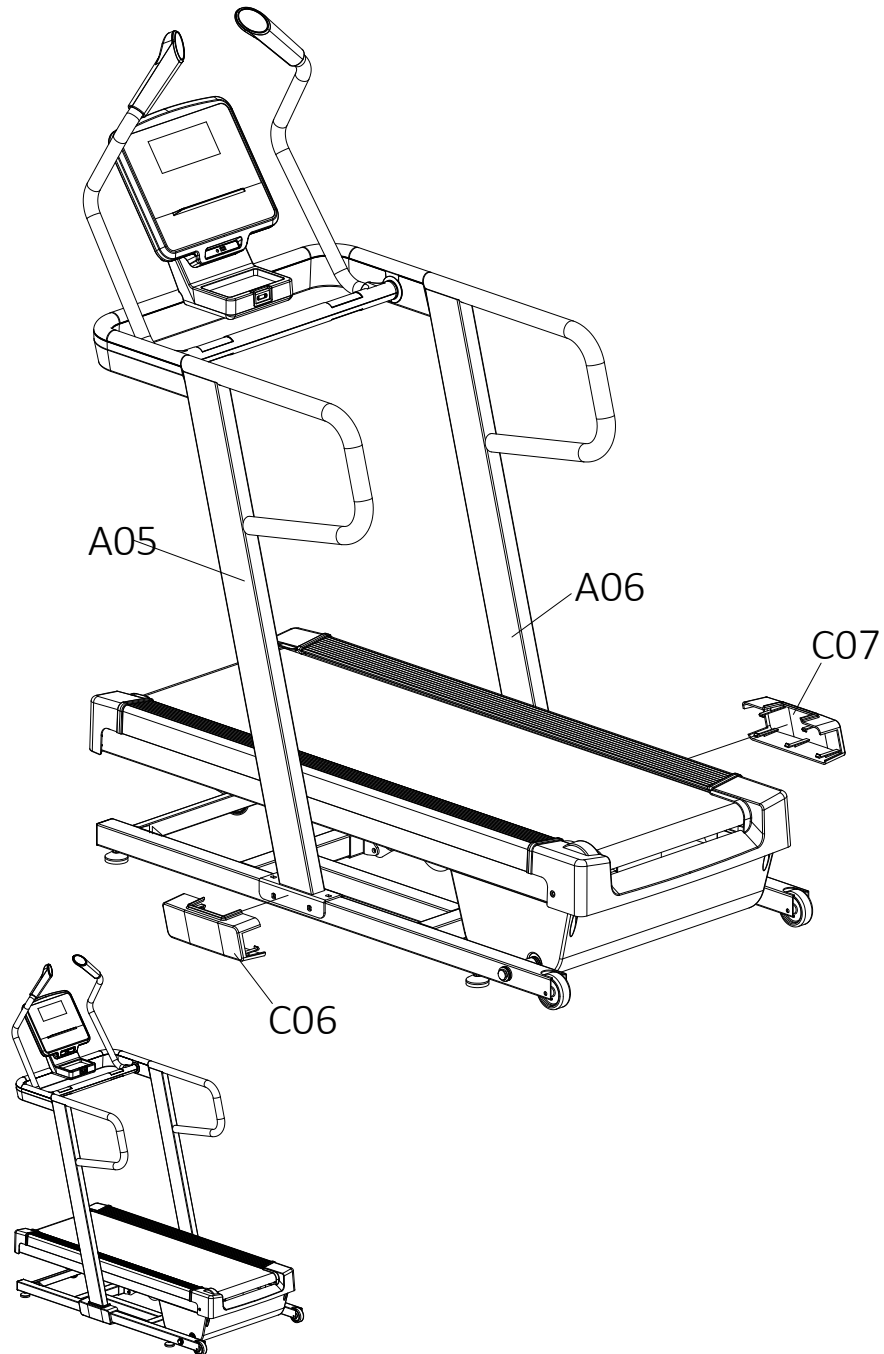

## STEP 10

Turn the knob B04 in anti-clockwise until the wheels C19 leave the floor.

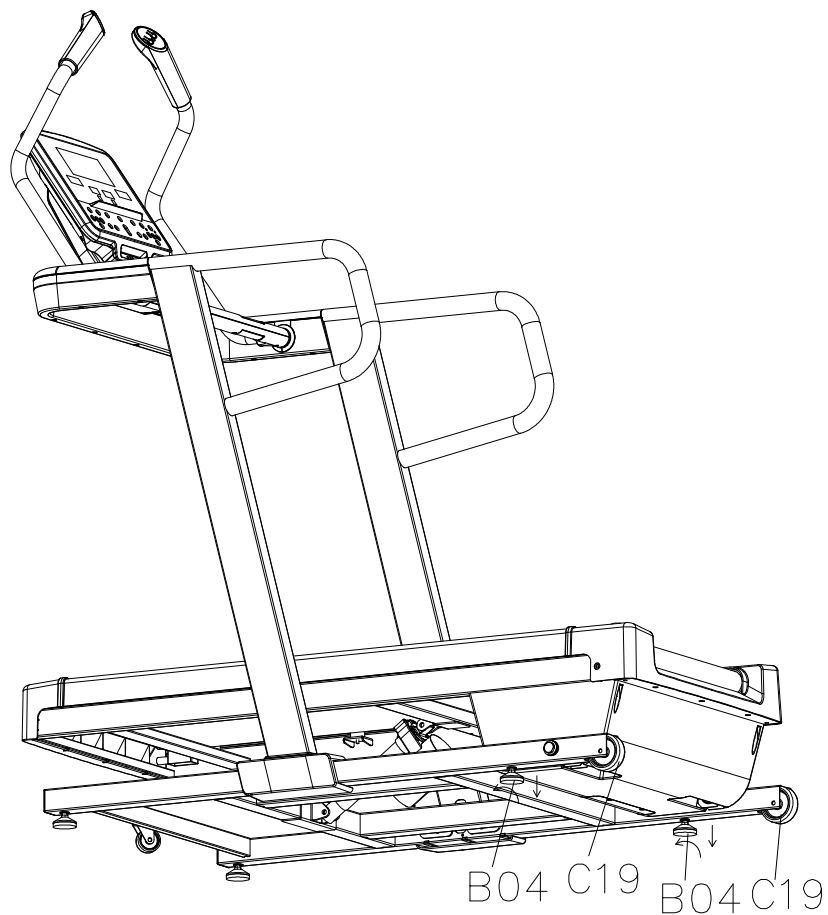

## STEP 11

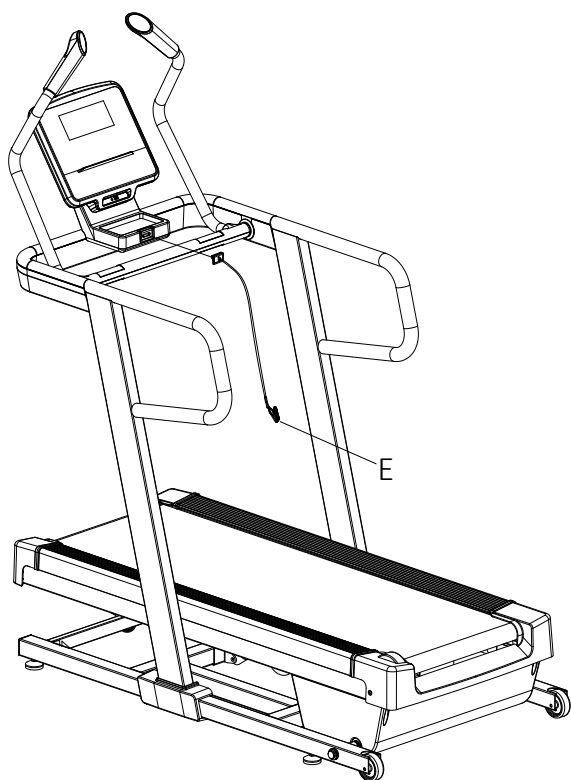

1. Please insert the safety key E into the safety key slot and nip the safety clip to your cloth.
2. For any emergency, please pull up the safety key rope , and the machine will stop.

# How to move the machine

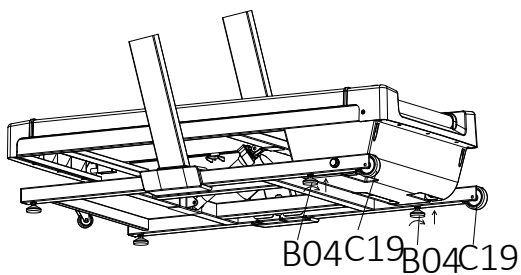

1. Turn the knobs B04 in clockwise to their highest position.

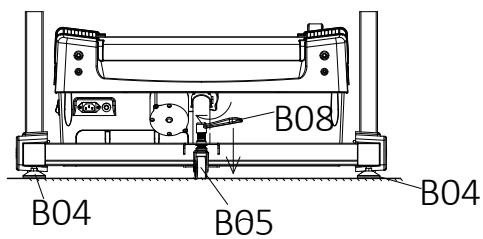

2. Turn the knob B08 in clockwise to its lowest position.

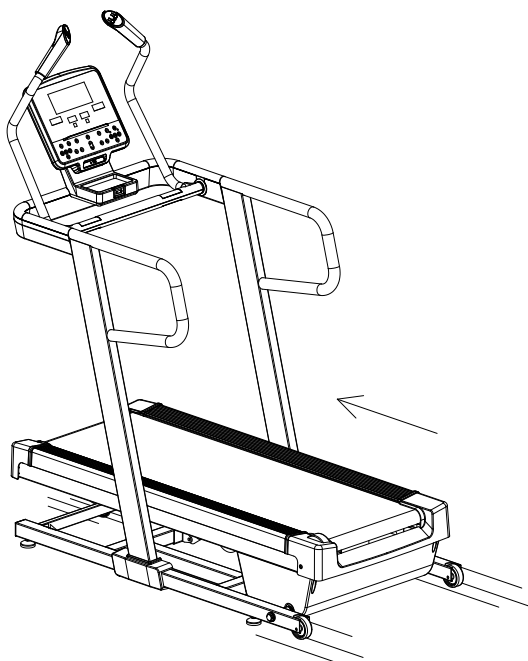

3. Move the treadmill.

# Operation introduction

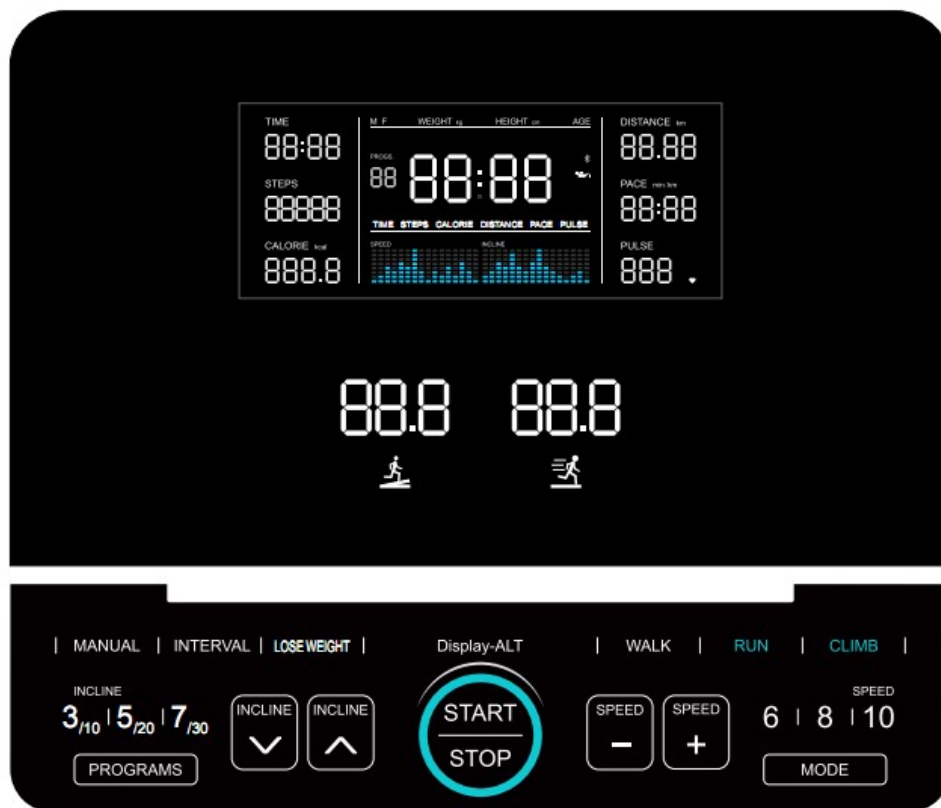

## 1. Windows display

- 1) **"TIME"** window: display time. Time play range is 0:00-18h.when get to the maximum time limit, it will not stop and count from 0:00 again. In countdown mode the display range is 99 mins-0 min. when reach to 0:00, time window will show "END", after 5 seconds it will stop and enter into standby mode. TIME and PACE will display alternately every 5 seconds.
- 2) **"DISTANCE"** window: Display the running distance. The display range is 0.00-99.99. when get to the maximum distance limit, it will not stop and count from 0:00 again. In countdown mode it will show from setting data to 0.00, when count to 0,the window will show "END", after 5 seconds it will stop and enter into standby mode. In FAT mode, it shows "FAT".
- 3) **"PACE"** window: Pace means how long it would take to finishing running 1km. Unit :min/km
- 4) **"CALORIES"** window: Display runner's calories worked out. Calories display range is 0.0-999. When get to the maximum calorie limit, it will not stop and count from 0.0 again. In calories countdown mode it will show from setting data to 0.0. When reach to 0.0, the window will show "END", after 5 seconds it will enter into standby mode.
- 5) **"PULSE"** window: Display current pulse. Hold the pulse sensors with both hands for 5 seconds to calculate and display the runner's heart beats per minute, the display range is 50-200 beats/min (This data is just for reference, and cannot be used as the medical data).
- 6) **"INCLINE"**: display current incline levels. Incline mode display range is -1-15. Run mode display range is -1-40 in CLIMB mode.
- 7) **"SPEED"**: display current speed.
- 8) **"STEPS"** window: Display running steps, the display range is 0-99999. In climb mode, this function will be shut off.
- 9) **Middle LCD window** : Display TIME, DISTANCE, SPEED,CALORIES and PULSE in turns with pressing DISPLAY-ALT button . Display "FAT" in FAT mode.

## 2. Button function

- 1) **"START"**: When getting through the power and safety key attached, press this button at any time to start the machine.
- 2) **"STOP"**: When running, press STOP button the machine will stop and all data recover to initial setting.
- 3) **"MODE"**: Press to choose running mode on standby mode: include time countdown mode"30:00", distance countdown mode"1.00", calorie countdown mode"50.0", step countdown mode"5000". The window will flash all the time when you choose the function. Press SPEED+/- or INCLINE+/- button to set the data and press START button to start running.
- 4) **"PROGRAM"**: press this key to choose suitable program. The programs are: P1(MANUAL), P2 (INTERVAL), P3 (LOSEWEIGHT), P4 (WALK), P5 , P6, P7, P8, P9, P10, P11, P12 and FAT. In climb mode you can choose P1-P6.
- 5) **QUICK PROGRAM BUTTONS**: You can choose P1(MANUAL),P2(INTERVAL),P3(LOSE WEIGHT),P4(WALK),P5 (RUN) and P6 (CLIMB) directly by quick program button "MANUAL" "INTERVAL" "LOSE WEIGHT" "WALK" "RUN" "CLIMB".
- 6) **"RUN"**: in standby mode, press this key and then the treadmill will enter into RUN mode. It is invalid in climb mode.
- 7) **"CLIMB"**: in standby mode, press this key and then the treadmill will enter into CLIMB mode. It is invalid in running mode.
- 8) **"-SPEED+ "**: In setting mode it can change the target data and in normal working mode it can change the speed by 0.1km/h per time. When you press "-SPEED+" key lasting for 0.5 sec the speed data will change continuously.
- 9) **"-INCLINE + "**: In setting mode it can change the target data and in normal working mode it can change the incline by 0.5 section per time. When you press "-INCLINE+" key lasting for 0.5 sec the incline data will change continuously.
- 10) **"SPEED 6 8 10"**: Speed quick buttons, press to choose speed 6, 8 and 10 directly.
- 11) **"INCLINE 3/10, 5/20, 7/30"**: Incline quick buttons, press to choose incline section 3, 5 and 7 directly in RUN mode, and in CLIMB mode, press the keys it will change to 10,20,30.

## 3. Quick start

- 1) Open the power switch; insert the magnet end of the safety pulling rope to the computer.
- 2) Press the "START" key and then the machine will work with speed 0.8km/h after the beeper countdown from 3 to 1.
- 3) According to your need you can change the speed and incline by pressing "-SPEED+" and "-INCLINE+" separately.

## 4. Manual mode

- 1) Press "START" in standby mode, the machine will work at speed of 0.8km/h and all other windows will count from 0. Press "-SPEED+" to change the speed and press "-INCLINE+" to change the incline.
- 2) In standby mode press the "MODE" key to enter into time countdown mode. "30:00" will be flashed in "TIME" window. Press "-SPEED+" or "-INCLINE+" to set target time from 5:00 to 99:00.
- 3) Press "MODE" 2 times to enter into distance countdown mode, and the window will show "1.00", press "-SPEED+" or "-INCLINE+" to set the target distance. Distance setting range is 0.50-99.90.
- 4) Press "MODE" 3 times to enter into calorie countdown mode. The window will show "50.0". Press "-SPEED+" or "-INCLINE+" to set the target calories. Calorie setting range is 10.0-999.
- 5) Press "START" to exercise after setting the countdown data. During exercise you can press "-SPEED+" or "-INCLINE+" to adjust the speed or incline. Press "STOP" key to stop the treadmill.

## 5. Quick program and built-in program

You can enter built-in program by pressing program quick buttons or press "PROGRAM". TIME window will display default running time "30:00" and flash all the time. You can change the running time by pressing "-SPEED+" or "-INCLINE+". Press "START" the machine will start after 3 seconds. Each program is divided into 16 sections. When the program enters into next section, system will beep; the speed and incline will change according to the program preset data. You can press "-SPEED+" or "-INCLINE+" to adjust the speed and incline. After completing a program, the system will beep and display "END". The machine will stop smoothly and return to standby mode after 5 seconds.

## 6. Program introduction

### 1) Program in RUN mode

PROGRAM \ SECTION		Time interval for each section= setting time/16															
		1	2	3	4	5	6	7	8	9	10	11	12	13	14	15	16
P1 (MANUAL)	SPEED	5	5	5	5	5	5	5	5	5	5	5	5	5	5	5	5
	INCLINE	2	2	2	2	2	2	2	2	2	2	2	2	2	2	2	2
P2 (INTERVAL)	SPEED	5	10	10	5	5	10	10	5	5	10	10	5	5	10	10	5
	INCLINE	2	2	4	4	6	6	6	6	4	4	4	4	2	2	2	2
P3 (LOSE WEIGHT)	SPEED	5	5	8	8	5	5	5	8	8	5	5	5	8	8	5	5
	INCLINE	2	2	4	4	4	4	4	4	4	4	4	4	2	2	2	2
P4 (WALK)	SPEED	5	7	7	8	8	7	7	10	10	7	5	5	7	7	10	5
	INCLINE	2	2	4	4	4	4	4	4	4	4	4	4	2	2	2	2
P5	SPEED	5	9	9	11	11	12	5	5	9	9	11	11	12	9	9	5
	INCLINE	2	2	4	4	4	4	4	4	4	4	4	4	2	2	2	2
P6	SPEED	5	7	8	10	12	10	8	5	5	8	10	12	10	8	7	5
	INCLINE	2	2	4	4	6	6	6	6	4	4	4	4	2	2	2	2
P7	SPEED	5	6	6	6	7	8	10	10	8	9	10	10	8	6	5	5
	INCLINE	0	5	5	5	4	4	4	3	3	3	3	4	4	4	0	0
P8	SPEED	5	5	5	5	6	7	5	6	7	5	6	7	5	5	5	5
	INCLINE	0	4	4	4	3	3	6	6	6	7	7	8	8	9	0	0
P9	SPEED	5	5	5	8	9	9	6	8	9	6	8	9	6	6	5	5
	INCLINE	0	5	5	5	6	6	6	7	8	9	9	9	10	10	0	0
P10	SPEED	5	6	6	9	9	6	9	10	6	10	11	11	6	6	5	5
	INCLINE	0	5	5	6	6	6	4	4	6	6	5	5	8	8	0	0

P11	SPEED	5	6	7	8	9	7	6	8	10	10	8	8	7	6	5	5
	INCLINE	0	6	6	6	7	5	8	8	4	4	4	5	5	8	0	0
P12	SPEED	5	7	10	12	9	9	12	12	9	9	12	12	7	7	5	5
	INCLINE	0	5	3	2	6	6	2	2	2	2	2	4	5	6	0	0

## 2) Program in CLIMB mode

PROGRAM	SECTION	Time interval for each section= setting time/16															
		1	2	3	4	5	6	7	8	9	10	11	12	13	14	15	16
P1 (MANUAL)	SPEED	2	2	2	2	2	2	2	2	2	2	2	2	2	2	2	2
	INCLINE	10	10	10	10	10	10	10	10	10	10	10	10	10	10	10	10
P2 (INTERVAL)	SPEED	2	5	5	2	2	5	5	2	2	5	5	2	2	5	5	2
	INCLINE	10	10	20	20	30	30	30	30	20	20	20	20	10	10	10	10
P3 (LOSE WEIGHT)	SPEED	2	2	4	4	2	2	2	4	4	2	2	2	4	4	2	2
	INCLINE	10	10	20	20	20	20	20	20	20	20	20	20	10	10	10	10
P4 (WALK)	SPEED	2	3	3	4	4	3	3	5	5	3	2	2	3	3	5	2
	INCLINE	2	2	4	4	4	4	4	4	4	4	4	4	2	2	2	2
P5	SPEED	2	5	5	6	6	6	2	2	5	5	6	6	6	5	5	2
	INCLINE	10	10	20	20	20	20	20	20	20	20	20	20	10	10	10	10
P6	SPEED	2	3	4	5	6	5	4	2	2	4	5	6	5	4	3	2
	INCLINE	10	10	20	20	30	30	30	30	20	20	20	20	10	10	10	10

## 7. Manual program:

MANUAL is self-define program. User can create personal workout, one self-define program is available.

### 1) Manual program setting

Press "MANUAL" or "PORGRAM" to enter into MANUAL program in standby mode. The PROG window will shows "U1" and TIME window will shows default time "30:00". You can reset running time by pressing "-SPEED+" or "-INCLINE+". After set the running time, press "MODE" to set the speed and incline of each section. Time interval for each section= setting time/16. Press "-SPEED+" to set the speed and "-INCLINE+" to set the incline. Then press "MODE" to save the data and move to set the next section until finish. The data will be saved all the time before you change it.

2) Start of the MANUAL program:

Press "MANUAL" to enter into the MANUAL model ,and then keeping press PROGRAMS button until the display show U1,at this time, you can press START button to start .

3) MANUAL program setup instructions

Each program is divided into 16 time periods. When setting, the speed, slope and running time of the 16 time periods should be set before pressing "start" button to start the treadmill.

## 8. Body fat test

- 1) Press "PROGRAMS" continuously in standby mode till the distance window show "FAT".
- 2) Press "MODE" enter F-1 to input sex by pressing "-SPEED+" (01-male 02-female).
- 3) Press "MODE" enter F-2 to input age by pressing "-SPEED+" (age range: 10 – 99).
- 4) Press "MODE" enter F-3 to input height by Pressing "-SPEED+" (height range: 100 – 200).
- 5) Press "MODE" enter F-4 to input weight by pressing "-SPEED+" (height range 20 -150).
- 6) Press "MODE" enter F-5. When the F5 window display "---", keeps your hands holding the hand pulse sheet, the window will display your body fat index in 8 seconds.
- 7) The best body fat index is between 20 and 25. If the index less than 19 it means you are underweight; if the index between 26 and 29 it means you are overweight. If more than 30 it means you are too fat (the following data is only for reference, please don't use as medical purpose).

F-1	Sex	01-male	02-female
F-2	Age	10-99	
F-3	Height	100-200	
F-4	Weight	20-150	
F-5	FAT	≤19	Thin
		=(20---25)	Normal
		=(26---29)	A little weight
		≥30	Too fat



## 9. HRC program

AGE	BPM			AGE	H	DEFAULT	L	AGE	H	SEFAULT	L
	H	DEFAULT	L								
15	195	123	123	35	176	111	111	58	154	97	97
16	194	122	122	36	175	110	110	59	153	97	97
17	193	122	122	37	174	110	110	60	152	96	96
18	192	121	121	38	173	109	109	61	151	95	95
19	191	121	121	39	172	109	109	62	150	95	95
20	190	120	120	40	171	108	108	63	149	94	94
21	189	119	119	41	170	107	107	64	148	94	94
22	188	119	119	42	169	107	107	65	147	93	93
23	187	118	118	43	168	106	106	66	146	92	92
24	186	118	118	44	167	106	106	67	145	92	92
25	185	117	117	45	166	105	105	68	144	91	91
26	184	116	116	46	165	104	104	69	143	91	91
27	183	116	116	47	164	103	103	70	143	90	90
28	182	115	115	48	163	103	103	71	142	90	89
29	181	115	115	49	162	103	103	72	141	90	89
30	181	114	114	50	162	102	102	73	140	90	88
31	180	113	113	51	161	101	101	74	139	90	88
32	179	113	113	52	160	101	101	75	138	90	87
33	178	112	112	53	159	100	100	76	137	90	86
34	177	112	112	54	158	100	100	77	136	90	86
				55	157	99	99	78	135	90	85
				56	156	98	98	79	134	90	85
				57	155	98	98	80	133	90	84

L-H: heart rate range (lowest-highest).

- 1) In standby mode, press "MODE" button continuously until HRC appears in distance window.

Note: If you press "START" directly under HRC mode, the system will recommend a parameter under age 30 target heart rate 114 and max speed 10Km/h.

- 2) After choose HRC program, press "MODE" for three seconds to enter into age setting. Time window will show default age 30.  
You can reset by pressing "-INCLINE+" and "-SPEED+" buttons. Age setting range is from 15 to 80.
- 3) After setting age, press "MODE", system will recommend a suitable target heart rate for reference. You can reset from 84 to 195 by pressing "-INCLINE+" or "-SPEED+".
- 4) After setting target heart rate, press "MODE" to set maximum speed by pressing "-INCLINE+" or "-SPEED+". Speed setting range is 3.0-18.0 Km/h.
- 5) After setting maximum speed, press "MODE" to enter into time setting. "TIME" window will show default time 10:00, press "-INCLINE+" or "-SPEED+" to reset from 10:00 to 99:00.
- 6) After setting the above data, press "MODE" to enter standby mode and press "START" to begin exercise.  
All the setting data is for single use, when finish running, the data will be swept off.
- 7) You can adjust the incline and speed during exercise by "-SPEED+" and "-INCLINE+". But the system will change the speed and incline automatically according to the target heart rate.
- 8) The exercise will start with speed 3.0km/h and system will detect your heart rate signal every 20 seconds,  
  
If detected heart rate is less than the 90% of the target heart rate, speed will accelerate 1.0km/h.  
  
If detected heart rate is less than the 95% of the target heart rate, speed will accelerate 0.5km/h.  
  
If detected heart rate is less than the 97% of the target heart rate, speed will accelerate 0.3km/h.  
  
If detected heart rate is between 97%-103% of the target heart rate, speed will not change.  
  
Instead if the detected heart rate is more than 110% of the target heart rate, speed will decrease 1.0km/h.  
  
If detected heart rate is more than 105% of the target heart rate, speed will decrease 0.5km/h.  
  
If detected heart rate is more than 103% of the target heart rate, speed will decrease 0.3km/h.  
  
If detected heart rate is between 97%-103% of the target heart rate, speed will not change.  
  
When reach the max speed, but the heart rate is more than 103% or less than 97% of the target heart rate, system will decrease or increase incline by 1 step or increase 1 step until the heart rate is between 97%-103% of the target heart rate.  
  
If there is no heart rate signal lasts for more than 30 seconds, system will show "NO HR", after 20 seconds still no signal detected, the treadmill will be stop.

**Note: 1. Heart rate control program only available when chest belt is used, and chest belt must stick closely to your chest and skin.**

**2. Playing music or video with fast tempo and changeful rhythm may disturb heart rate detection.**

## 10. Safety key function

Pull off the safety key in any time the machine will stop immediately. Meanwhile all window shows “---“and the beeper alarms

To start the treadmill again, insert the magnet end of Safety Key into the console and press “START”.

## 11. USB charging

You can charge your electronic devices during exercise through the USB slot .

## 12. MP3

You can connect your mobile phone with MP3 wire to play music, choose music and adjust the volume of music by your mobile phone buttons..

# Maintenance

**Warning: Before cleaning the machine, please make sure the power has been switched off.**

1. **Cleaning:** Wipe away the dust on the belt, running board and side footboard as excess dust may increase the friction on the belt and cause damage to the machine. It is recommended to clean the machine once a month.
2. **Lubrication:**
  - 1) Lubrication is needed per 300km. The machine will sound the alarm "di di di" and displays "OIL", at the same time the oil icon will be lit up to inform you to oil. Please lubricate the oil on the middle of the running belt.
  - 2) After lubrication press the STOP key for more than 3 seconds in standby mode and then the machine will sweep off the alarm and lubrication information.

We suggest you lubricate the machine as the following method:

People who use the treadmill less than 3 hours per week, please lubricate the machine per 6 months

People who use the treadmill less than 3-5 hours per week, please lubricate the machine per 3 months

3. People who use the treadmill more than 5 hours per week, please lubricate the machine per 2 months
4. Running belt is off-center: The Running belt may become off-center after using for a period of time. First allow the machine to run by itself and the belt may centralize automatically. If it does not centralize automatically, you can adjust the position of the belt by screwing the bolt shown in the images below. If the running belt has shifted to the right, you need to tighten the screw on the right of the belt or loosen the screw on the left. If the belt has moved to the left, do the opposite.
5. Belt Slipping: Please adjust bolts according to the diagram below. When adjusting the two sides make sure each adjustment is the same, on either side of the treadmill. We recommend adjusting by half a turn until the running belt does not slip or deviate. Avoid making the belt too tight as this may damage it.

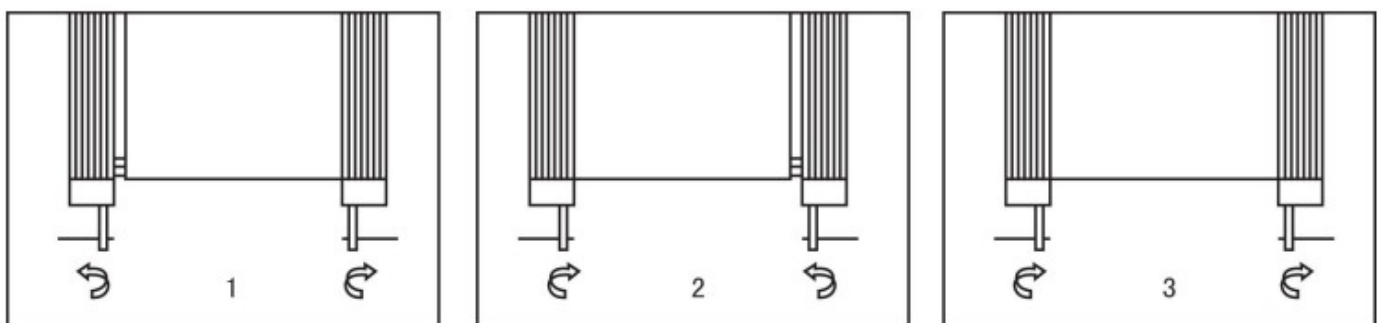

Attention: In order to prolong the lifespan of the treadmill, we suggest switch off the treadmill for about 10 minutes after 2 hours' exercising. Running belt is too loose or tight will do harm to the treadmill. So keep a suitable tightness is very important. We suggest you grasp the running belt and pull it up to a certain distance until you cannot pull it up anymore. If the distance is between 50-75mm, we think the tightness of the running belt is suitable.

# Explosive drawing

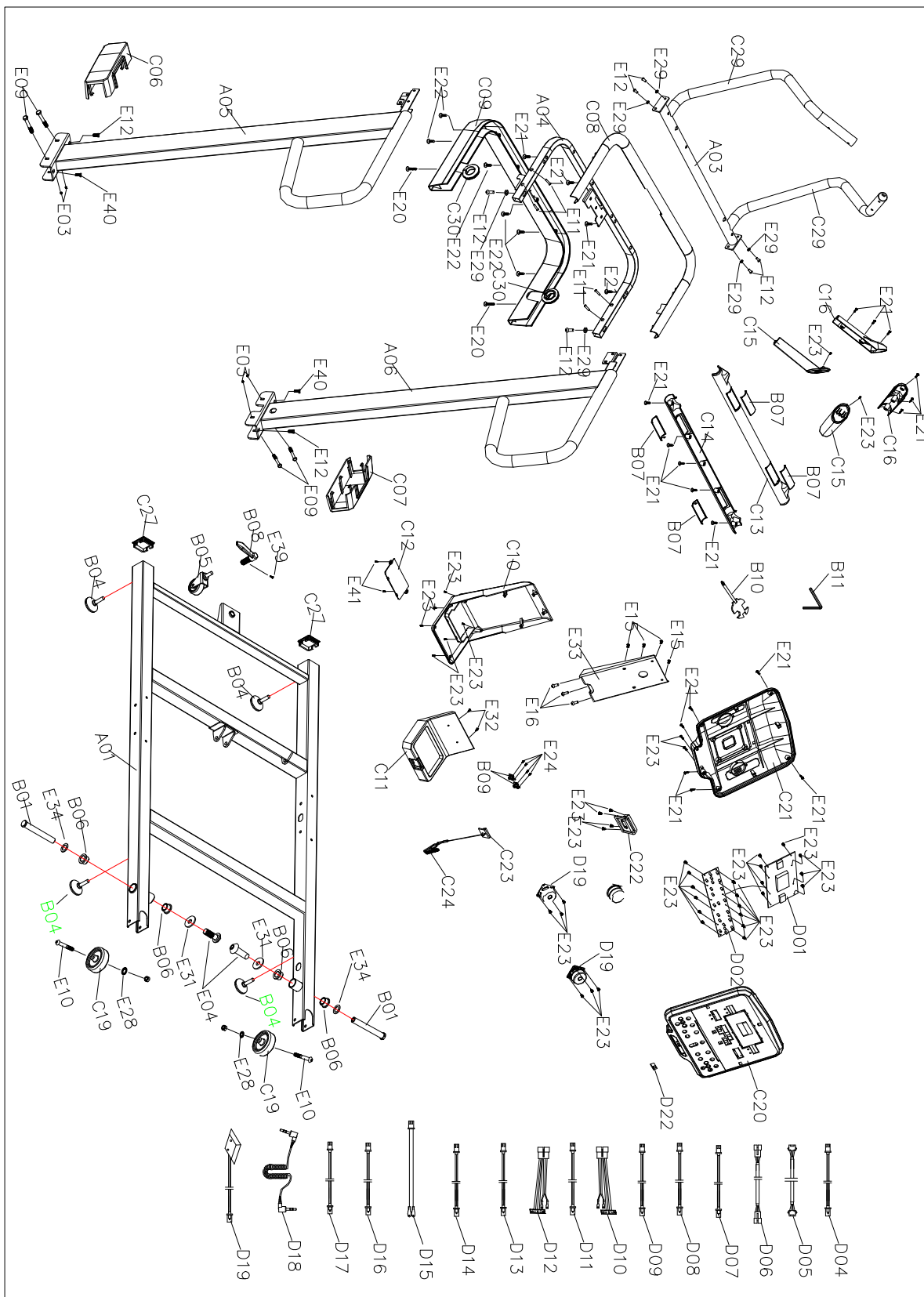

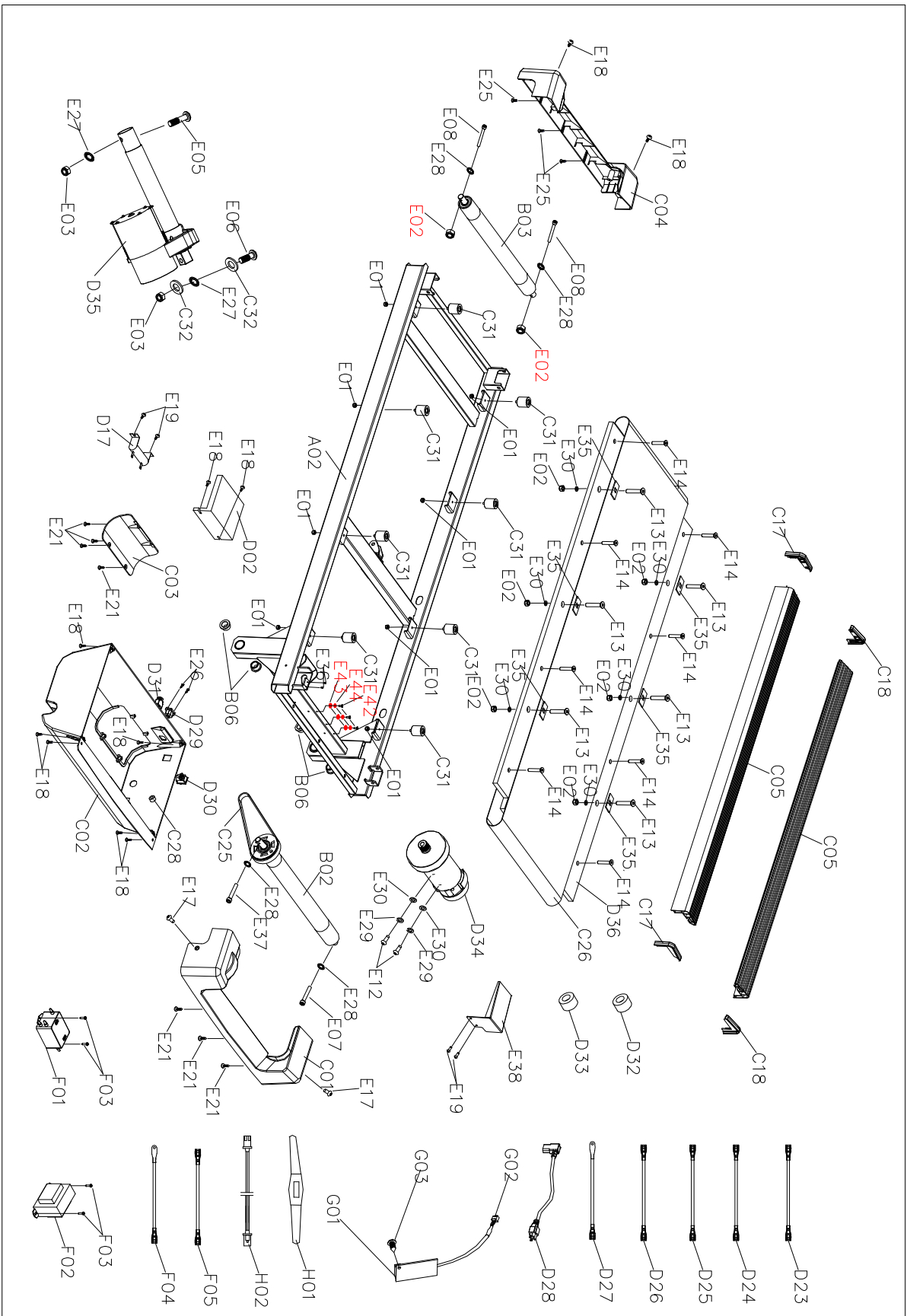

# Part list

NO.	Description	Spec	QTY	NO.	Description	Spec	QTY
A01	Bottom frame		1	C23	Safety key		1
A02	Mainframe		1	C24	Safety key clip		1
A03	Middle handlebar		1	C25	V-belt		1
A04	Display support frame		1	C26	Running belt		1
A05	Left upright column		1	C27	Square end cap		2
A06	Right upright column		1	C28	Annular bushing plug		1
B01	Rotation shaft		2	C29	Foam		2
B02	Front roller		1	C30	Circular cap		2
B03	Rear roller		1	C31	Black cushion		8
B04	Adjustable knob		2	D01	Display		1
B05	Universal wheel		1	D02	Control board		1
B06	Alloyed axle sleeve		8	D03	Key board		1
B07	Handle pulse sheet		4	D04	Display wire		1
B08	Handle knob		1	D05	Display upper wire		1
B09	Safety key shrapnel		2	D06	Display extension wire		1
B10	Cross solid wrench		1	D07	Display bottom wire		1
B11	5# inner hex wrench		1	D08	Speed control upper wire		1
B12	Wrench		1	D09	Speed control extension wire		1
B13	Allen wrench		1	D10	Speed control bottom wire		1
C01	Top motor cover		1	D11	Incline control upper wire		1
C02	Bottom motor cover		1	D12	Incline control extension wire		1
C03	Decoration cover		1	D13	Incline control bottom wire		1
C04	Rear cover		1	D14	Resistance		1
C05	Side rail		2	D15	Safety key upper wire		1
C06	Left bottom cover		1	D16	Safety key bottom wire		1
C07	Right bottom cover		1	D17	Audio wire		1
C08	Display support top cover		1	D18	USB connection wire		1
C09	Display support bottom cover		1	D19	Speaker		2
C10	Display rear cover		1	D20	Mp3 connection wire		1
C11	Display front cover		1	D21	Sensor		1
C12	Display bottom cover		1	D22	USB module		1
C13	Middle handlebar top cover		1	D23	AC single wire		1
C14	Middle handlebar bottom cover		1	D24	AC single wire		1
C15	Handlebar top cover		2	D25	AC single wire		1
C16	Handlebar bottom cover		2	D26	AC single wire		1
C17	Left decoration ring		2	D27	Earthed wire		1
C18	Right decoration ring		2	D28	Power cable		1
C19	Moving wheel		2	D29	Power socket		1
C20	Control panel top cover		1	D30	Square switch		1
C21	Control panel bottom cover		1	D31	Overload protector		1
C22	Safety key seat		1	D32	Magnetic ring		1

NO.	Description	Spec	QTY	NO.	Description	Spec	QTY
D33	Magnetic core		1	E20	Screw	ST4.2*25	2
D34	DC motor		1	E21	Screw	ST4.2*12	30
D35	Inclination motor		1	E22	Screw	ST4.2*20	6
D36	Running deck		1	E23	Screw	ST2.9*8	42
E01	Nut	M6	8	E24	Screw	ST2.5*6	4
E02	Nut	M8	10	E25	Screw	ST4.2*12	6
E03	Nut	M10	6	E26	Screw	ST2.9*8	2
E04	Bolt	M12*25	2	E27	Lock washer	10	2
E05	Bolt	M10*62	1	E28	Lock washer	8	6
E06	Bolt	M10*42	1	E29	Spring washer	8	8
E07	Bolt	M8*65	2	E30	Flat washer	8	2
E08	Bolt	M8*60	1	E31	Flat washer	12	2
E09	Bolt	M8*70	4	E32	Screw	ST4.2*8	2
E10	Bolt	M8*60	2	E33	Panel support board	ø3.0	1
E11	Bolt	M8*25	4	E34	Washer	ø2.0	2
E12	Bolt	M8*15	12	E35	Side rail fixation washer	ø3.0	6
E13	Bolt	M8*35	6	E36	Bolt	M3	2
E14	Bolt	M6*25	8	E37	Bolt	M8*70	1
E15	Bolt	M6*15	4	E38	Motor protective cover	ø2.0	1
E16	Bolt	M6*10	3	E39	Hexagon socket set screws with flat point	M4*6	1
E17	Bolt	M6*15	2	E40	Hex Bolt	M8*15	4
E18	Bolt	M5*15	10	E41	Cross recessed pan head tapping screws	ST2.9*16	2
E19	Bolt	M5*10	4				

### Optional part list

NO.	Description	Specification	QTY	NO.	Description	Specification	QTY
F01	Inductance	Optional parts for filter and inductor group	1	H01	HRC connection wire	Optional parts for HRC group	1
F02	Filter		1	H02	Wireless heart rate receiver		1
F03	Screw ST4.2*12		4				
F04	Earthed wire		1				
F05	Single wire 2		1				
G01	Bluetooth module	Optional parts for Bluetooth APP group	1				
G02	Bluetooth connection wire		1				
G03	Screw ST2.9*6		1				





GARLANDO SPA  
Via Regione Piemonte, 32 - Zona Industriale D1  
15068 - Pozzolo Formigaro (AL) - Italy  
[www.toorx.it](http://www.toorx.it) - [info@toorx.it](mailto:info@toorx.it)