

TCORX
FITNESS IN MOTION

INSTRUCTION



WBX40
MULTI FIT



Rev : 00

Ed : 03/17

PART LIST

PART NO:	DESCRIPTION	Q'TY
1.	Bottom tube	1
2.	Upright post	1
3.	Support tube	1
4.	Adjustable extension tube	1
5.	Arm curl tube	1
6.	Foam tube	1
7.	U shape tube	1
8.	Backrest tube	2
9.	Backrest	1
10.	Arm curl	1
11.	PVC cap	2
12.	End cap ϕ 50	4
13.	Outer bushing sleeve 50*45	1
14.	Release knob	2
15.	Foam	2
16.	End cap ϕ 25	2
17.	Pin ϕ 10*120	1
18.	End cap 25*25	6
19.	Hexangular Bolt M10*65	2
20.	Spacer ϕ 10	14
21.	Nut M10	7
22.	Hexangular Bolt M8*40	8
23.	Spacer ϕ 8	8
24.	Hexangular Bolt M10*70	1
25.	Hexangular Bolt M10*75	1
26.	Hexangular Bolt M10*115	1
27.	Hexangular Bolt M10*150	2
28.	Pin ϕ 10*85	1
29.	Axle sleeve	2
30.	End cap 45*45	1
31.	End cap 50*50	1
32.	End cap 25*50	4

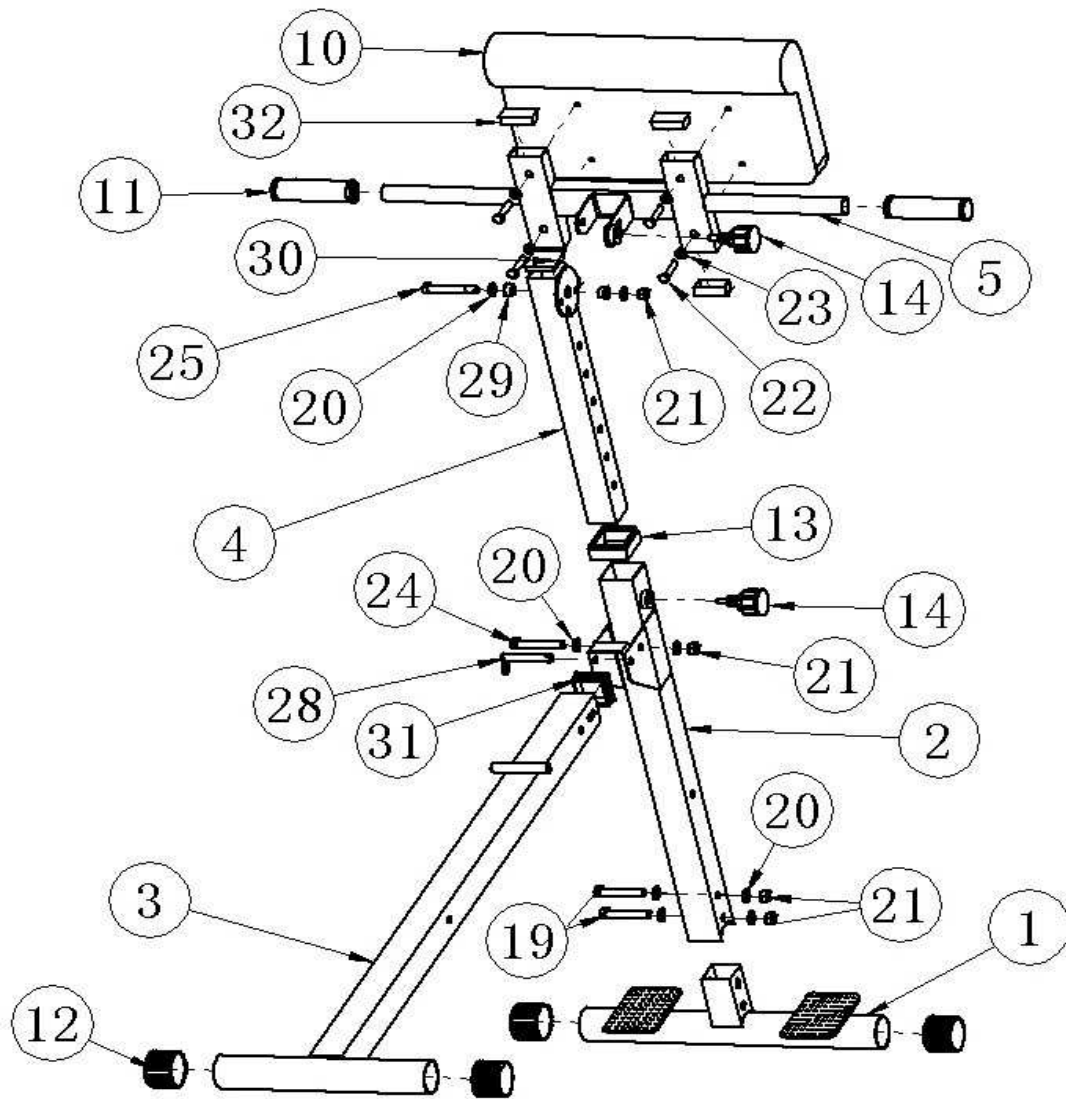

STEP 1

1. Insert the end caps (12) into the front & rear tubes (1), then assemble (2) to (1) and screw it by (19, 20, 21) ; Insert (31) into (3) and assemble the caps (12) to (3) and attach (3) to (2) fixed by (24, 20, 21), finally insert 28, see picture;
2. Attach (13) to (2), then insert (4) to (2), and then screw (14) to adjust the height and fix, then attach (29) to (4), and attach (32) to (5), assemble two caps (11) to two sides of (5); Connect and fix (5) & (4) by (25, 20, 21), then screw (14); Finally, attach the pad (10) to (5) by bolts (22, 23), see above picture.

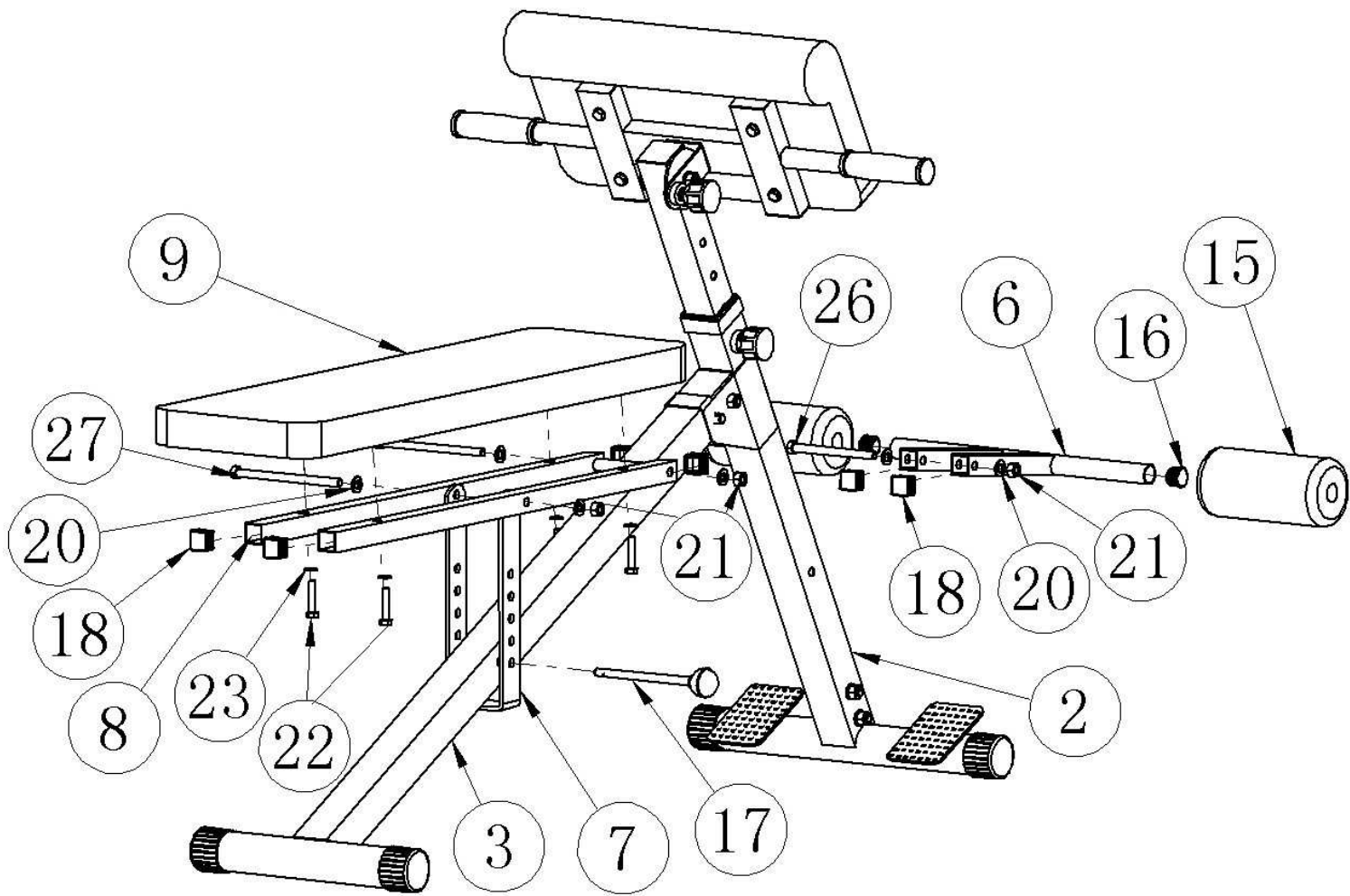

STEP 2

1. Insert (18) to (8), connect (8) by (27, 20, 21) to (3), then fix (7) to (8) by (27, 20, 21); Connecting (3) and (7) by (17), and fix (9) to (8) by (22, 23), see above picture.

2. Insert (18) to (6), fix (6) to (2) by (26, 20, 21), put (16) to two ends of (6), finally assemble (15), see above picture.



GARLANDO SPA
Via Regione Piemonte, 32 - Zona Industriale D1
15068 - Pozzolo Formigaro (AL) - Italy
www.toorx.it - info@toorx.it