

TCORX

FITNESS IN MOTION



TX-POWER SPD

Power Meter pedals SPD System

INSTRUCTION



Cod : GRLDTCORXTXPWMSPD

Rev: 00

Ed : 10/2024

Package contents

- | | |
|------------------------------|-----------------------|
| a. Pedal Body | e. Tension Adjuster |
| b. Front Binding (fixed) | f. Cleats x 2 |
| c. Axle | g. Cleat washers x 2 |
| d. Rear Binding (adjustable) | h. M5 Cleat bolts x 4 |

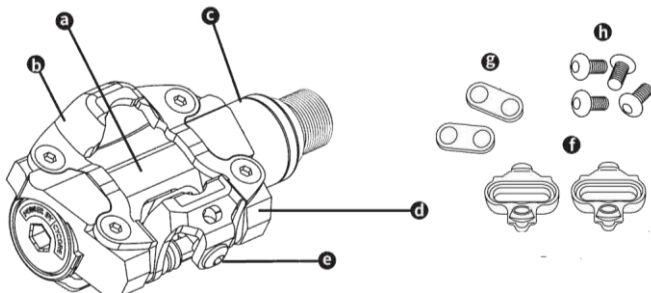

Specifications

	Product detail
Operating Temperature	0°C ~ 40°C
Storage Temperature	0°C ~ 40°C
Weight	211g/ pc including battery
Size	82.5mm x 54.4mm x 42mm
Battery type	CR2032 3V (1pc for each pedal) NOTE: Please change the battery on both side pedal at the same time.
Durability	Up to 100 hours
Water Resistance	IPX7
Wireless protocols	Bluetooth 4.0 / ANT+
Product of origin	Made in Taiwan

Tools required

6mm or 8mm Allen Key, (depending on pedal model),
4mm Allen Key, 6mm Allen key.



Pedal installation

Noted: Please see the instruction and install your pedal properly to avoid damage. The Left pedal is marked with the letter "L" and the right pedal with the letter "R". It is important step to identify the proper pedal because the left pedal tightens in counter-clockwise and the right pedal tightens clockwise.

By using a little bike grease on the pedal arm, it can make installation smoother. Use the 5mm hex, the right pedal screws onto the crank clockwise and the left pedal screws onto the crank counterclockwise.

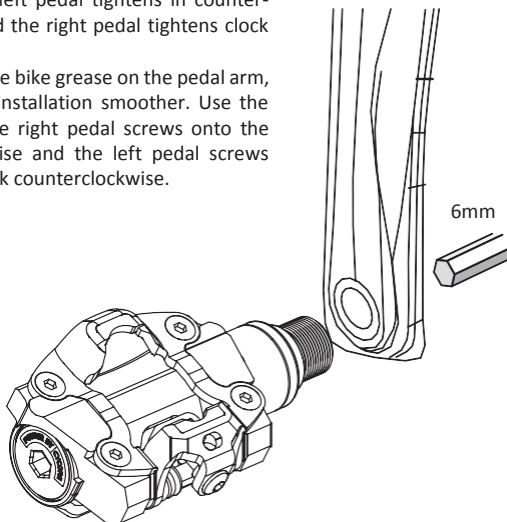

Cleat Installation

Left and right cleats are identical – the pointed end faces the toe of the shoe.

1. Lightly lubricate cleat bolt threads with oil
2. Using the 4mm Allen key attach cleat bolts and cleat washers loosely to shoe soles. The lateral center line of the cleat should be aligned with the center of the ball of the shoe sole. Adjust vertically via slots in shoe sole. Adjust horizontally via play between cleat washer and cleat.
3. Tighten cleats very firmly, but avoid excessive force. Tightening torque: 50-80 khf/cm (43-69 lb-in) Cleat position can be fine-tuned to preference after trial rides. It may take some time to find your optimum cleat set-up.

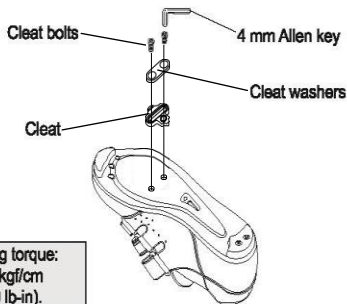

Tightening torque:
50–80 kgf/cm
(43–69 lb-in).

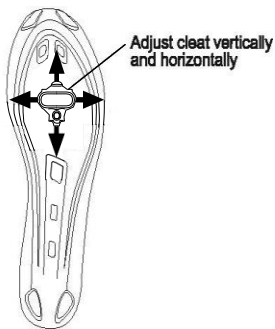

Pedal adjustment and shoe/pedal use

Depending on the model of your pedals, the tension adjuster is located on the rear binding, or on the top of the pedal body. To adjust rear binding tension, use a 3mm Allen key to turn tension adjuster.

Adjustable rear binding tension

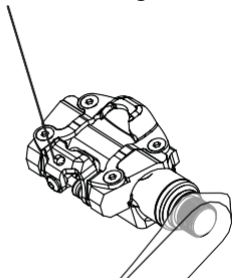

Binding adjustment range :
Max 15 Nm

1. Increase tension in a clockwise direction (+) (for a more secure shoe/pedal bind, but more difficult engagement and disengagement).
2. Decrease tension in a counter-clockwise direction (-) (for less secure shoe/pedal bind but easier engagement and disengagement).

Engage cleat shoes in pedals by aligning the cleat between front and rear binding while pushing down. Disengage by twisting heel outwards (away from bicycle).

Adjustable rear binding tension

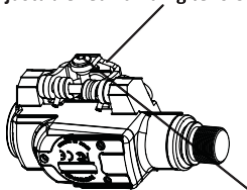

Tension adjuster

Decrease Increase



3mm Allen key

Do not over-tighten or over-loosen tension adjuster (over-tighten may damage thread, and bolt may fall out if too loose).

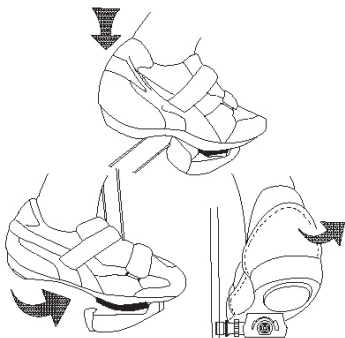

Pedal Status LED

LED Activity	Status
Blue light flashes	Both pedals are waking up.
Alternating blue and green flashes	Left pedal is pairing to right pedal.
Blue flashes every seconds	Left pedal is detecting right pedal.
Blue light flashes twice every second (total 5 times)	Zero reset (calibration) is successful.
Blue light flashes once every second (total 5 times)	Crank setting is successful.
Blue light a long time	Hardware issue
Green flashes every seconds	Left pedal is connecting with right pedal
Red light flashes three times in every 5 seconds	Pedals are in low batteries.
Red light a long time	Hardware issue
Alternating red and blue flashes	Hardware issue
Green on left pedal Blue on right pedal	Left pedal is not pair to right pedal

Pairing

Pedal need to be paired one side at a time. It does not matter which side paired first. The pedal includes BLE and ANT+ protocols, pair the pedal to any device using either of these protocols.

1. The distance of the bike computer and the sensor can't exceed 3m.
2. Activate bike computer and entering SETTING to pair with power pedals.
3. Turn the crank a few turns and it will automatically pair with bike computer.
Pedal will automatically activate by turning the pedal or starting a ride with flashing blue light.

Calibration

It is essential to conduct a zero-offset procedure upon initial use or following the detachment of the device to ensure the acquisition of precise data.

While zero-offset need not be performed before each ride, it is advisable to execute the zero-offset calibration periodically.

Please see the following steps for zero reset of power pedal:

1. Spin the cranks backwards a few times to wake up the power meter.
2. In order to have the calibration successful, please make sure both power pedal connect successfully each other with green flashing light displaying on the left pedal.
3. Position the cranks should be as vertical as possible to the ground (the left pedal must to at 6 o'clock and the right one at 12 o'clock.) for accurate calibration.
4. Download our APP, find the calibration page and select Calibrate.
5. You should receive the message saying "Calibration Successful."

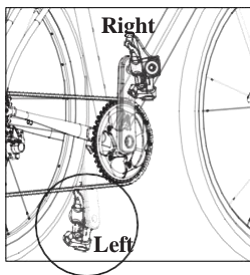

Battery

CR2032x1 (one side)

1. Use a phillips screwdriver to remove the battery cover.
2. Gently press the edge of the battery on the outside of the pedal to remove and recycle the battery.
3. Wait 5 to 10 seconds.
4. Insert new battery into the power meter in clean/dry environment.
5. Replace battery cover and do not overwind.

NOTE: Do not damage or lose the O-ring gasket.

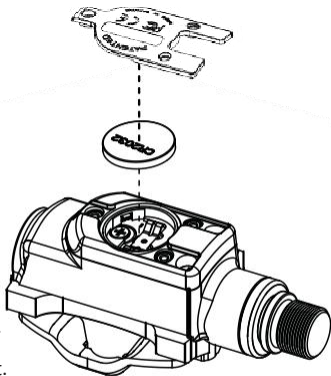

Pair to Smart phone

1. Download “Ride for Life” from Google play or App Store.

Google Play



App Store



2. Open the APP



3. Go into SETTING , then go to page that display BLE CONNECT, below ID will appear.



1. On the smart phone look for the same ID number which shows on the computer.

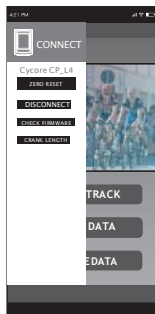
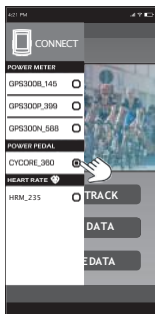
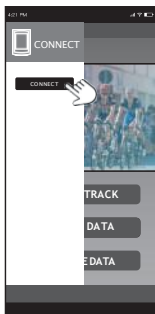

2. Press RECEIVE DATE, press the green RECEIVE box again. Files will start receiving and a list of files which you had already record will be shown.

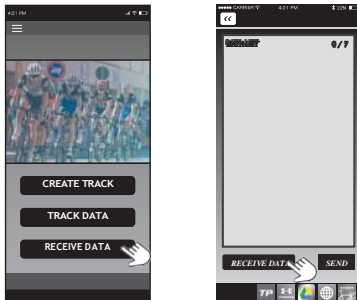

3. If you would like to upload the files to Strava, press the box of the file and press the box of the file and press the Strava icon the bottom right hand.

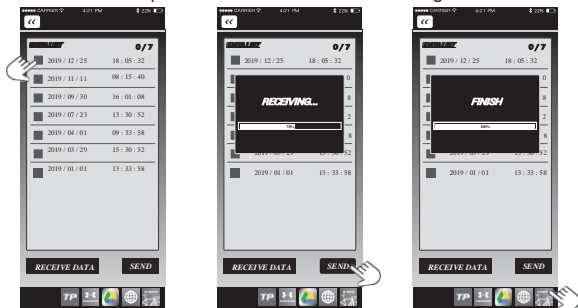

4. Log in to Strava first once all the steps are finish, there would be a little green check on the Strava icon, then press SEND. Upload will start and the date will be removed automatically after uploading.



Caution

External interference may be caused by other electronic devices, such as nearby televisions, stereos, speakers, wires and cables, etc. If you experience interference in power pedal, try moving your pedal away from the area of potential radio interference. Relocate the pedal away from any devices that may interfere with RF signals, such as DVD players or televisions.

- Make sure to keep the pedal clean and clear of any dirt or dust.
- Don't use sharp objects to clean the device, as they can harm it.
- Steer clear of using strong chemicals, solvents, or bug sprays because they can harm the plastic parts and the device's finish.
- Don't dunk the pedal in water or use high-pressure water to clean them.
- Avoid storing the device in places with really hot or really cold temperatures for a long time, as it can cause permanent damage.

Troubleshooting

Q1. Power pedal LED not flashing after install battery?

- Check your battery whether it has enough power;
Reinstall the battery on the Power pedal. If the flashing blue light means correctly start functioning.

Q2. When the power data is not stable

- Ensure the pedals are installed correctly. Incorrect installation can lead to power measurement discrepancies.
- Make sure your first calibration the left crank is toward 6 o'clock direction and right crank is toward 12 o'clock direction.
- Check if the pedal sensors are clean and positioned correctly on the crank arms. Dirt or misalignment can impact accuracy.
- Crank-Arm Length Consideration: It's important to note that the length of your crank-arm directly impacts the calculation of power. Utilizing an incorrect crank-arm measurement can result in inaccurate power readings. For guidance on adjusting your crank-arm length, please refer to your bike computer's manual. If your bike computer does not offering this feature, you can easily configure it through app.
- Double-Check Your Saddle Height: Verify that your saddle height is correctly adjusted to your regular riding position. Proper saddle height is crucial to release the right force point with ensuring the accuracy of the power readings.

Q3. When the hardware issued lights appear, such as, red and blue light all the time or alternating of red and blue light.

- Try to remove the battery and insert it after one minute.

Q4. When encountering the failing calibration or no working after the calibration.

- Please check if both pedals are waked up with blue light flashing before calibration.

Precautions

To keep the pedals in good condition, do not approach to the strong magnets which mean if the pedals are close to the strong magnets, they may perform the atypical data. Avoid soaking the pedals in water or use the high pressure squirt to clean up the pedals. Also, some hazardous substance will cause damage to the pedals like toxic solvents. Please make sure the pedals are under normal use usage.

Warranty

During the warranty period, under the normal use and maintenance, the pedal will be free from physical defects in material and workmanship. We provide limited warranty only to the person or entity that originally purchased the product from our authorized dealer or its authorized distributor or retailer. Warranty period may differ regionally; please kindly check with the retailer at the time of purchase.

Warranty does not apply, if

- The warranty period is expired.
- Normal wear and tear.
- Unauthorized alternation to or change of parts or components of the product.
- Damage, malfunctions, or abnormalities caused by human factors, force majeure, accident, misuse of the product, improper maintenance, improper assembly, or failure to follow the instructions or warnings in the user manual.

The warranty stated herein explicitly replaces any other warranties, including but not limited to implied warranty of merchantability and/or fitness for a particular purpose. In no event shall we be liable for any direct, indirect, incidental, consequential or special damages, arising from or related to the use of this manual or the product described herein.



GARLANDO SPA
Via Regione Piemonte, 32 - Zona Industriale D1
15068 - Pozzolo Formigaro (AL) - Italy
www.toorx.it - info@toorx.it